



JK-900E

Parts Manual

零件手册

 **杰克缝纫机**
JACK SEWING MACHINE
| [HTTP://WWW.CHINAJACK.COM](http://www.chinajack.com) |

目录/CONTENTS

使用说明/Use Manual	1
一、机壳部分/Machine Bed Frame	4
二、机壳机罩部件(1)/Cover(1)	6
三、机壳机罩部件(2)/Cover(2)	8
四、主轴部件/Crankshaft Drive Mechanism	10
五、夹线部件/Thread Tension Mechanism	12
六、过线机构(1)/Thread Guide and Thread Takeup(1)	14
七、过线机构(2)/Thread Guide and Thread Takeup(2)	16
八、过线机构(3)/Thread Guide and Thread Takeup(3)	18
九、针杆部件(1)/Needle Drive Mechanism(1)	20
十、针杆部件(2)/Needle Drive Mechanism(2)	22
十一、针杆部件(3)/Needle Drive Mechanism(3)	24
十二、上弯针部件/Upper Looper Drive Mechanism	26
十三、下弯针部件/Lower Looper Drive Mechanism	28
十四、二重环弯针机构(1)/Chainstitch Looper Drive Mechanism(1)	30
十五、二重环弯针机构(2)/Chainstitch Looper Drive Mechanism(2)	32
十六、差动调节机构/Feed Mechanism	34
十七、送布机构/Feed Mechanism	36
十八、剪布机构/Knife Drive Mechanism	38
十九、抬压脚机构/Presser Foot Mechanism	40
二十、供油机构(1)/Lubrication Mechanism(1)	42
二十一、供油机构(2)/Lubrication Mechanism(2)	44
二十二、HR装置机构部件/H.R.Device	46
二十三、线架部件/Thread Stand	48
二十四、托盘部件/Part For Semi-Submerged Installation	50
二十五、专用零件/Specific Parts	52
二十六、专用零件/Specific Parts	54
二十七、随机附件部分/Accessories Assemblies	56
标准零件度量表/Standard measurement part list	58

给HR装置供油

为了防止布纤维或线被切断,请尽早给HR装置供油。

注:关于购买硅酯油,请咨询缝纫机代销店或与本公司营业所联系。

Filling the HR device with silicon oil

Fill the device with oil before it is too low in order to prevent needle thread breakage and fabric damage.

Note: Use recommended silicon oil [UNION CARBIDE CORPORATION] UCC-L45(10)

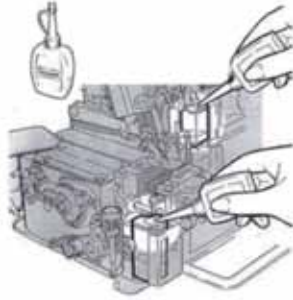

穿线的方法

打开压脚杆及机盖(三处)

把机上原有的线与缝纫用线绑结在一起。

Threading

Open three covers.

Sewing the presser foot aside.

Knot the preset thread and the thread being used together to thread the machine.

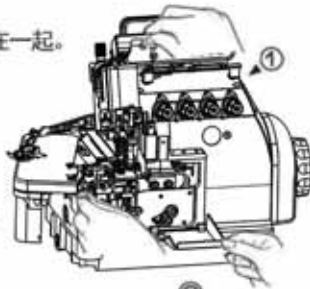

针线

将线拉到针眼前,剪掉结头再次穿好针线。

Needle thread

Trim the knots off neatly before passing through the eye of the needle to rethread.

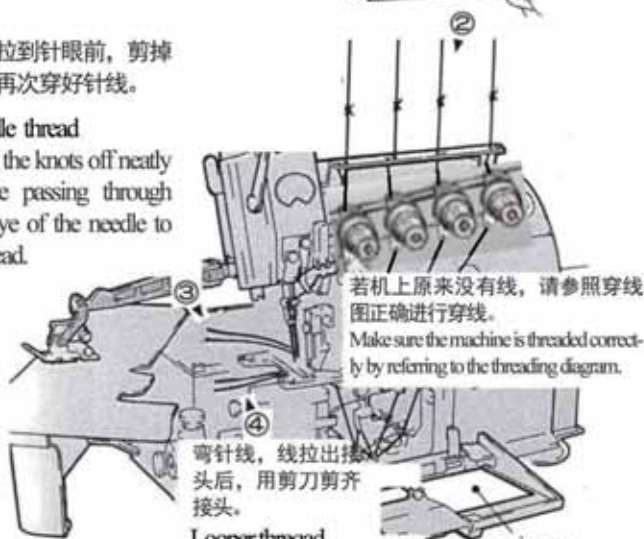

若机上原来没有线,请参照穿线图正确进行穿线。
Make sure the machine is threaded correctly by referring to the threading diagram.

弯针线,线拉出接头后,用剪刀剪齐接头。

Looper thread
Trim the knots off neatly after passing through the eye of the looper

过线图
Threading diagram

压脚压力调节

压脚压力的调节,松动螺母①,调节螺母②。在送布得到稳定状态下尽可能使用较弱的

Adjusting the presser foot pressure

Loosen adjusting nut① and then turn adjusting nut② to adjust the presser foot pressure.

It should be as light as possible in the feed situation when the steady state was obtained.

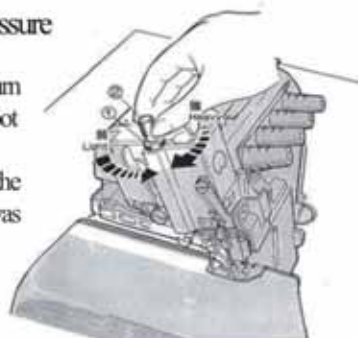

差动比的调节

差动比的调节松开螺母①调节螺母②。

Adjusting the diff. feed ratio

Loosen the adjusting nut① and turn the adjusting nut② to adjust the differential feed ratio.

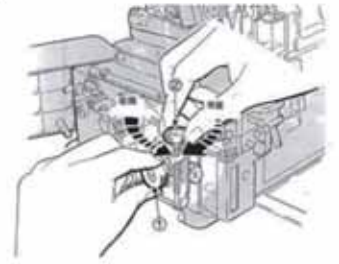

针脚长度的调节

1.摁住按钮,旋转手轮,按钮会陷进更深处。

2.这时边摁住按钮,边转动手轮,使校准标记号对准所希望的数值。

注:针脚长度的调节务必请在调节差动比之后进行。

Adjusting the stitch length

1. While pressing the push button, turn the handwheel to seek the position at which the push button goes further into the depth.

2. Then, keeping the push button pressed, turn the handwheel and set the desired scale to the aligning mark.

Note: Stitch length adjustment must only be made after the differential feed ratio has been adjusted.

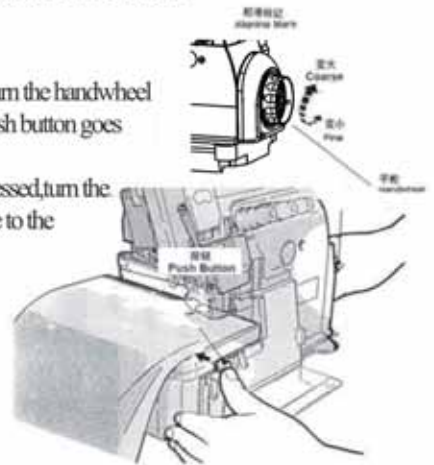

线状态的调节

线张力状态的调节,请用机针线调节螺帽①,上弯针线调节螺帽②,下弯针线调节螺帽③来进行调节。

Adjusting the thread tension

Make tension adjustments with the needle thread knob①, the upper looper knob②, and the lower looper knob③.



缝纫机的清扫

缝纫机的清扫,以针板槽及送布牙周围为主。

Cleaning the machine

Mainly the slots of the needle plate and the feed rows should be cleaned.

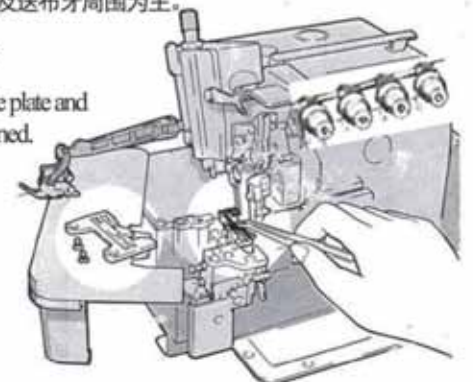

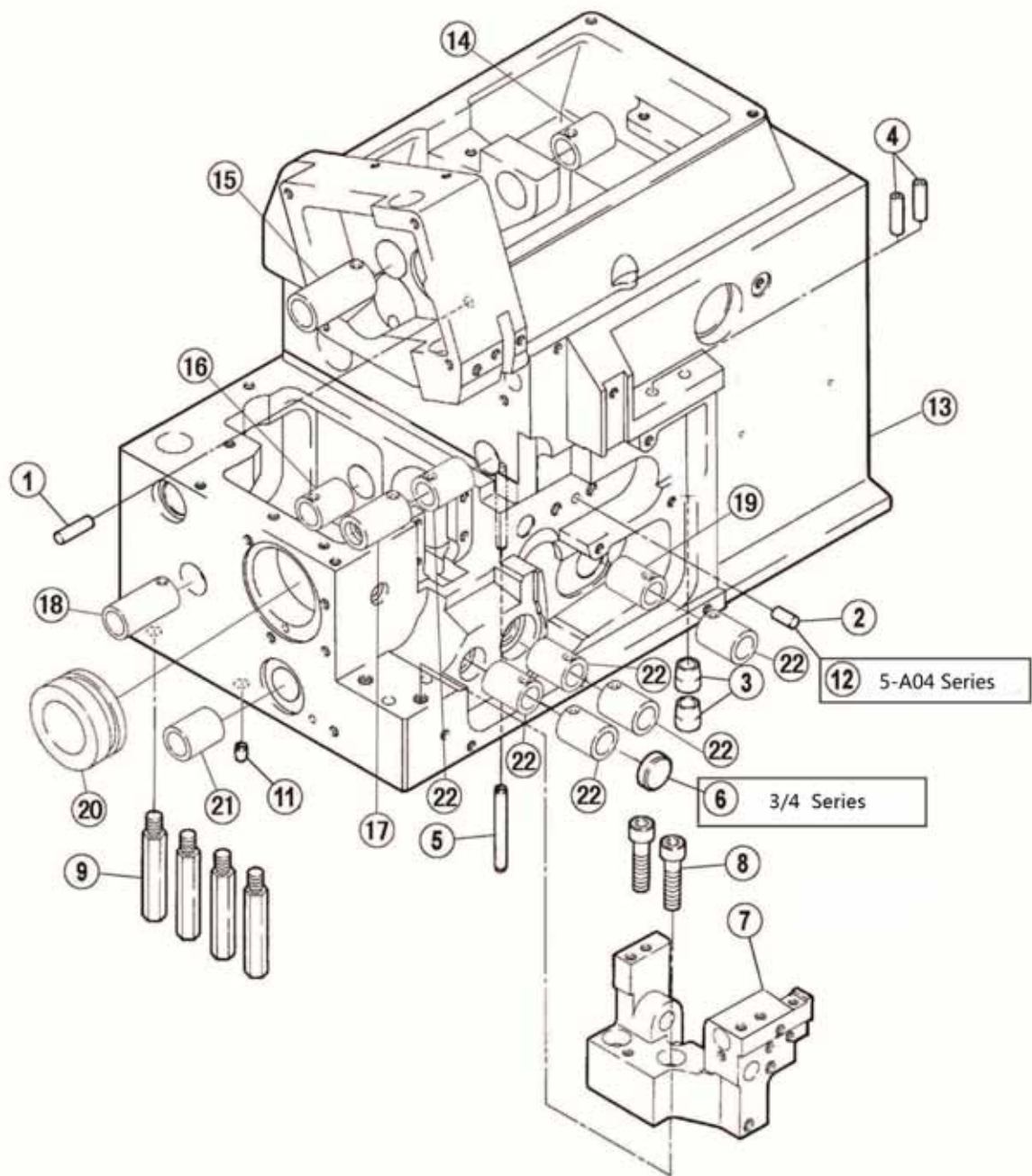

一、机壳部分/Machine Bed Frame

序号 NO.	公司件号 Part NO.	参考件号 Ref.Part No.	名称	Description	数量 (Number)		
					三线 three-thread	四线 four-thread	五线 five-thread
1	P03010	240333	销5 × 16	Pin	1	1	1
2	P03017	201002	销5 × 10	Pin	1	1	1
3	20711001	210194	导向套	Indicator guide	2	2	2
4	20713027	240325	过线管	Pipe	2	2	2
5	P03018	240299	销4 × 40	Pin	1	1	1
6	20628023	208173	送布轴油封	Plug	1	1	0
7	20701002	270008-91	下刀座	Bracket Assembly	1	1	1
8	207S13003	4511	螺钉M6 × 25	Screw	2	2	2
9	206S30001	270047	支柱	Bed pin	4	4	4
11	20126001	----	工艺孔销	Pin	1	1	1
12	20726009	----	厚料摇杆定位销	Pin	0	0	1
13	302790	----	机壳	Machine Bed Complete	1	1	1
14	20703001	----	上轴右套	Sleeve	1	1	1
15	20703002	----	上轴左套	Sleeve	1	1	1
16	20703003	----	送布右轴套	Sleeve	1	1	1
17	20703004	----	上刀轴左套	Sleeve	1	1	1
18	20703009	----	上刀轴右套	Sleeve	1	1	1
19	20703006	----	上弯针后轴套	Sleeve	1	1	1
20	20703007	----	主轴轴套	Sleeve	1	1	1
21	20703008	----	差动轴套	Sleeve	1	1	1
22	20703009	----	上刀轴右套	Sleeve	4	4	6

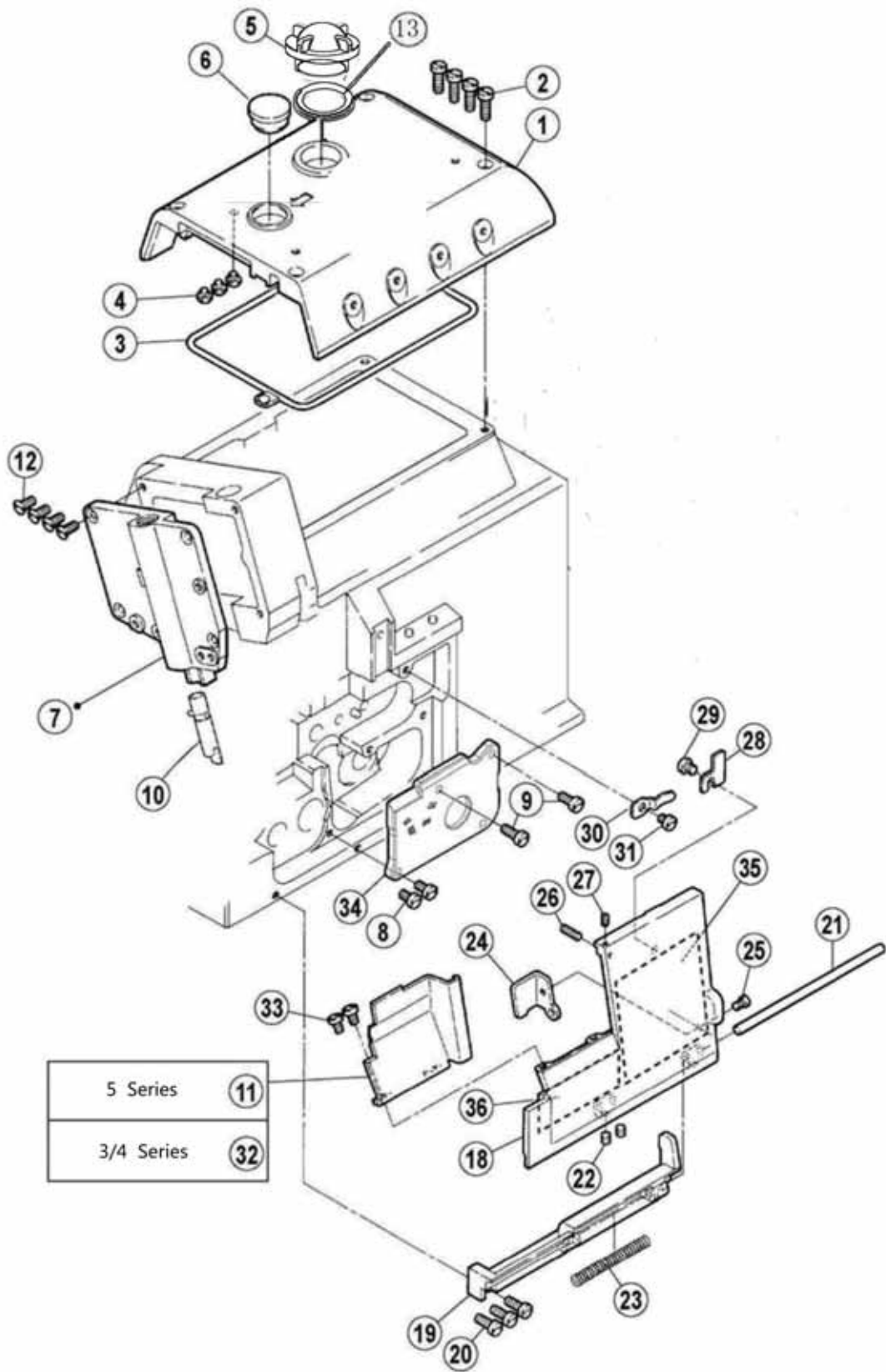

二、机壳机罩部件(1)/Cover(1)

序号 NO.	公司件号 Part NO.	参考件号 Ref.Part No.	名称	Description	数量 (Number)		
					三线 three-thread	四线 four-thread	五线 five-thread
1	300164	270020-SD	上罩	Top Cover	1	1	1
2	207S11012	7020	螺钉M4 × 10	Screw	4	4	4
3	20722001	270021	密封垫	Gasket	1	1	1
4	20622003	240305	减震垫	Cushion Rubber	3	3	3
5	20711055	----	油标盖	Oil sight window	1	1	1
6	20722002	240110	油塞	Plug	1	1	1
7	300165	270010-UD	侧盖	Side Cover	1	1	1
8	207S11012	7020	螺钉M4 × 10	Screw	2	2	2
9	207S11008	7021	螺钉M4 × 12	Screw	2	2	2
10	2070201100	274011-91	压脚杆组件	Presser Bar	1	1	1
11	20712043	270013	左前盖	Front Cover(left)	0	0	1
12	207S17001	7044	螺钉M4 × 10	Screw	4	4	4
13	21022003	----	油标盖垫	Oil level gauge washer	1	1	1
18	300166	270011-UD	右前盖	Front Cover(right)	1	1	1
19	20701006	270014	铰链	Hinge	1	1	1
20	207S11008	7021	螺钉M4 × 12	Screw	3	3	3
21	20626001	240043	铰链销	Pin	1	1	1
22	207S14001	4543	螺钉M4 × 4	Screw	2	2	2
23	20627001	240301	铰链销弹簧	Spring	1	1	1
24	20712002	270018	锁紧板	Latch	1	1	1
25	207S11009	7009	螺钉M3 × 2.5	Screw	1	1	1
26	207S14002	4574	螺钉M3 × 12	Screw	1	1	1
27	207S14003	4535	螺钉M3 × 4	Screw	1	1	1
28	20712003	270017	锁紧板	Latch	1	1	1
29	S01031	7017	螺钉M4 × 4.7	Screw	1	1	1
30	20612004	210044	前罩板卡簧1	Flat Spring	1	1	1
31	S01031	7017	螺钉M4 × 4.7	Screw	1	1	1
32	20712004	270012	左前盖	Front Cover(left)	1	1	0
33	207S11011	7018	螺钉M4 × 5	Screw	2	2	2
34	20712005	270028	前盖板	Side Cover	1	1	1
35	xxxxxxxx	----	穿线图	Threading diagram	1	1	1
36	xxxxxxxx	----	穿线图	Threading diagram	0	0	1

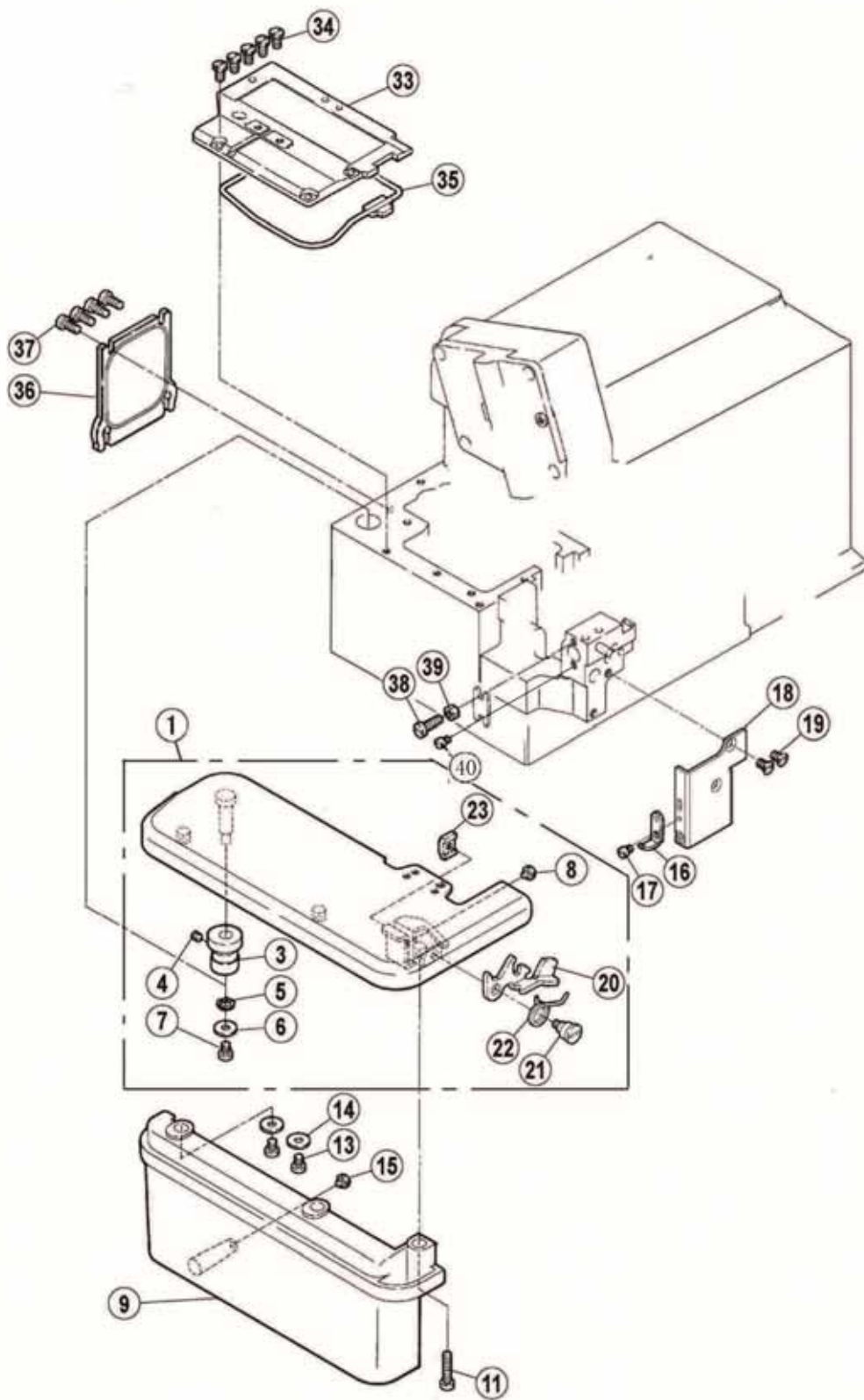

三、机壳机罩部件(2)/Cover(2)

序号 NO.	公司件号 Part NO.	参考件号 Ref.Part No.	名称	Description	数量 (Number)		
					三线 three-thread	四线 four-thread	五线 five-thread
1	2071220100	270035	缝台组件(宽)	Cloth Plate	1	1	1
3	20603016	270042	套筒	Bushing	1	1	1
4	207S14007	4543	螺钉M4×4	Screw	1	1	1
5	W02004	----	止动垫圈6	Washer	1	1	1
6	30228008	204115	垫圈	Washer	1	1	1
7	207S11011	7018	螺钉M4×5	Screw	1	1	1
8	20622003	240305	减震垫	Cushion Rubber	1	1	1
9	20711018	270030-UB	侧盖组件(宽)	Side Cover(Wide)	1	1	1
11	207S11013	7025	螺钉M4×17.5	Screw	1	1	1
12	W02002	201252	垫圈4	Spring Washer	1	1	1
13	S01002	7018	螺钉M4×5	Screw	2	2	2
14	20528017	240343	垫片	Washer	2	2	2
15	20622003	240305	减震垫	Cushion Rubber	1	1	1
16	20612016	270049	下刀座前垫护板	Latch	1	1	1
17	207S11014	7180	螺钉M3.5×4.5	Screw	1	1	1
18	20712008	270015	挡板	Plate	1	1	1
19	207S17003	7170	螺钉M4×7.5	Screw	2	2	2
20	20627002	270043	连杆	Lever	1	1	1
21	206S20006	7172	螺钉M4	Screw	1	1	1
22	20627003	270044	扭簧	Spring	1	1	1
23	20612009	270045	托架	Bracket	1	1	1
33	20701084	270022	上盖	Bed Cover Plate Assy.	1	1	1
34	207S12001	7084	螺钉M4×8	Screw	5	5	5
35	20722003	270023	密封垫	Gasket	1	1	1
36	2071201200	270026	后窗板	Cover Plate	1	1	1
37	S01005	7020	螺钉M4×10	Screw	4	4	4
38	207S11016	7023	螺钉M4×16	Screw	1	1	1
39	N01001	4821	螺母M4	Nut	1	1	1
40	207S11007	----	螺钉M4×7.5	Screw	1	1	1

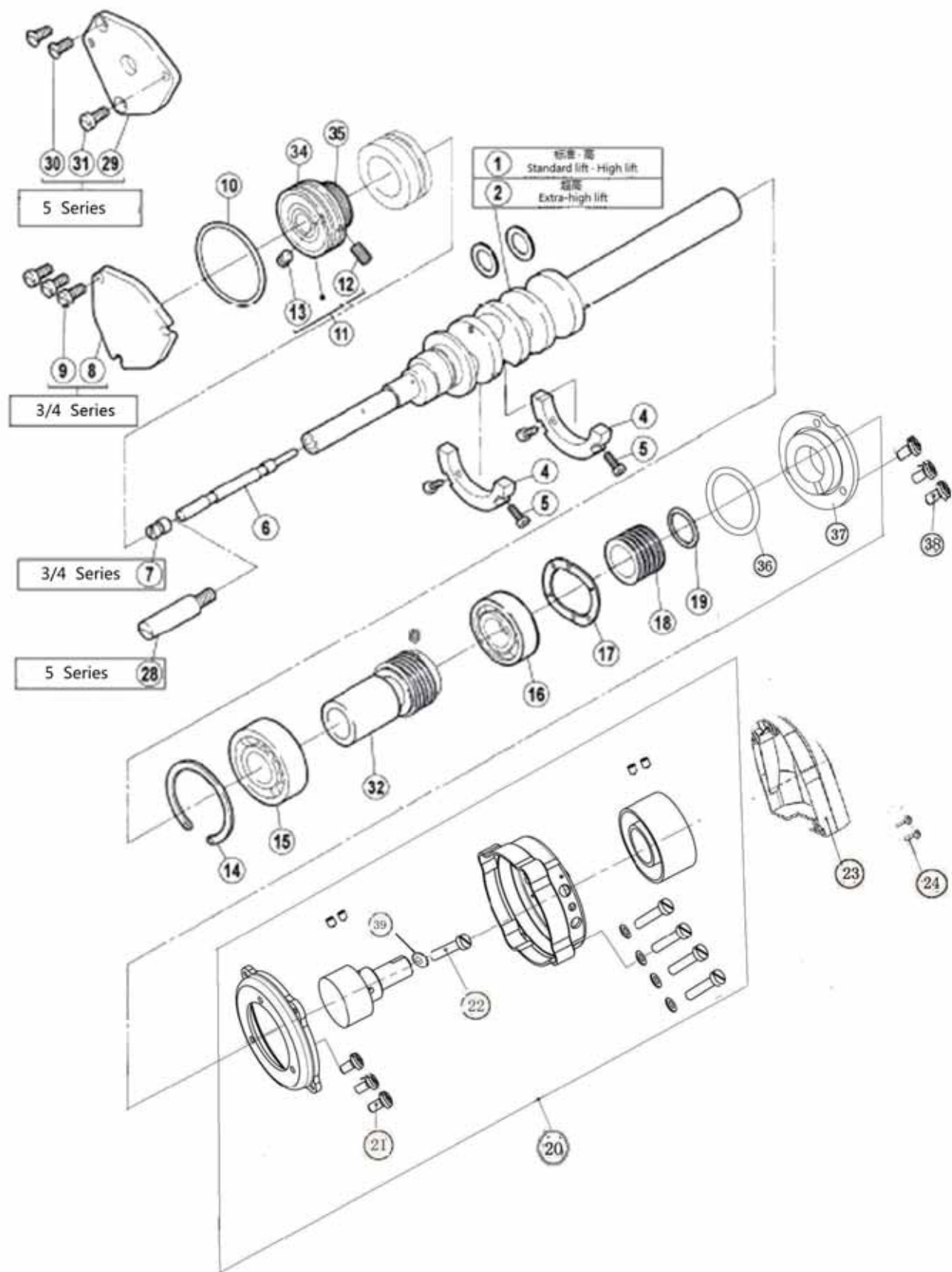

四、主轴部件/Crankshaft Drive Mechanism

序号 NO.	公司件号 Part NO.	参考件号 Ref.Part No.	名称	Description	数量 (Number)		
					三线 three-thread	四线 four-thread	五线 five-thread
1	400046	270500A	主轴	Crankshaft	1	1	0
2	400045	270500C	主轴	Crankshaft	0	0	1
4	20701008	270502	平衡块	Blance Weight	2	2	2
5	207S11017	7011	螺钉M3×8	Screw	4	4	4
6	20726002	270503	销	Pin	1	1	1
7	S10009	4541	螺钉M6×8	Screw	1	1	1
8	20712013	270508	前轴承盖	Cover	1	1	1
9	207S11007	7019	螺钉M4×7.5	Screw	3	3	3
10	001024	240340	O型圈40×1.8	O Ring	1	1	1
11	B04004	270507-91	轴承6202LB	Ball Bearing	1	1	1
12	207S11018	4572	螺钉M5×10	Screw	1	1	1
13	207S14012	4514	螺钉M5×5	Screw	1	1	1
14	20729001	240335	卡簧	Ring	1	1	1
15	B04005	211526	轴承6203LLU	Ball Bearing	1	1	1
16	B04005	211526	轴承6203LLU	Ball Bearing	1	1	1
17	W03003	240306	垫圈32	Washer	4	4	4
18	20103002	----	主轴中轴套	Oil Seal	1	1	1
19	001025	210057	O型圈17×1.8	O Ring	1	1	1
20	20133008	-----	直驱电机	Direct drive moter	1	1	1
21	S01011	-----	螺钉	Screw	3	3	3
22	201S11034	-----	螺钉SM15/64"×28	Screw SM15/64×28	1	1	1
23	20711056	-----	皮带轮罩	Cover	1	1	1
23	20711056	-----	皮带轮罩	Cover	1	1	1
24	207S11026	-----	螺钉M6×16	Screw	2	2	2
28	20602002	270510	主轴接轴	Pin	0	0	1
29	20712046	270509	前轴承盖	Cover	0	0	1
30	207S17001	7044	螺钉M4×10	Screw	0	0	2
31	207S11012	7020	螺钉M4×10	Screw	0	0	1
32	20708003	272523A0	轴套	Spacer	1	1	1
34	001037	----	O型圈30×1.2	O Ring	2	2	2
35	20725001	----	棘轮	Ratchet	1	1	1
36	001028	240307	O型圈41×1.8	O Ring	1	1	1
37	20708015	----	后轴承盖	Rigth Cover	1	1	1
38	207S11012	7020	螺钉M4×10	O Ring	3	3	3
39	W02004	----	垫片	Washer	1	1	1

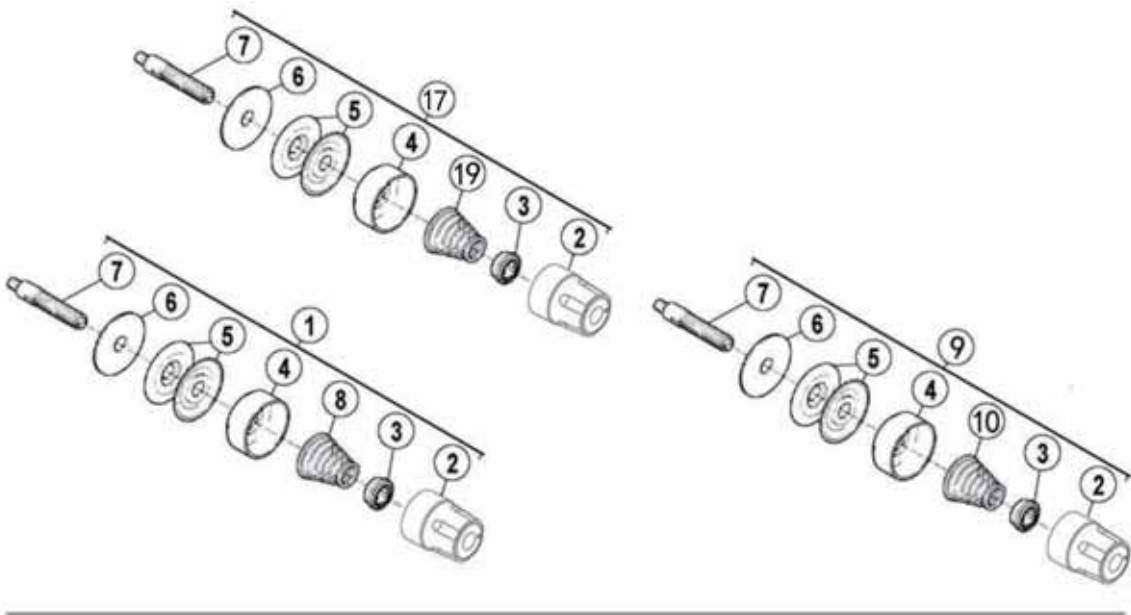

■ 1 针 (1-needle)

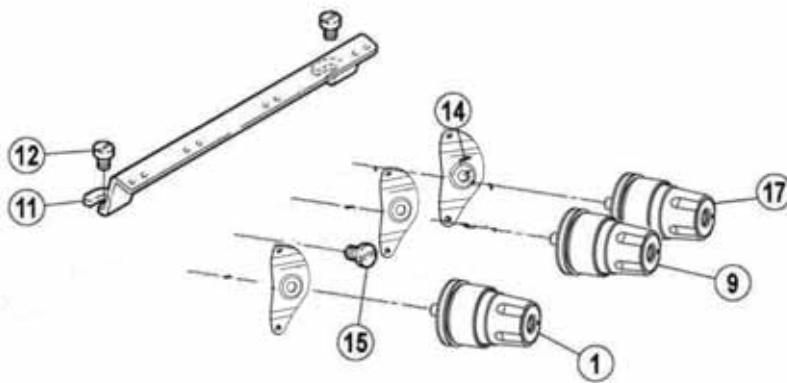

■ 2 针 (2-needle)

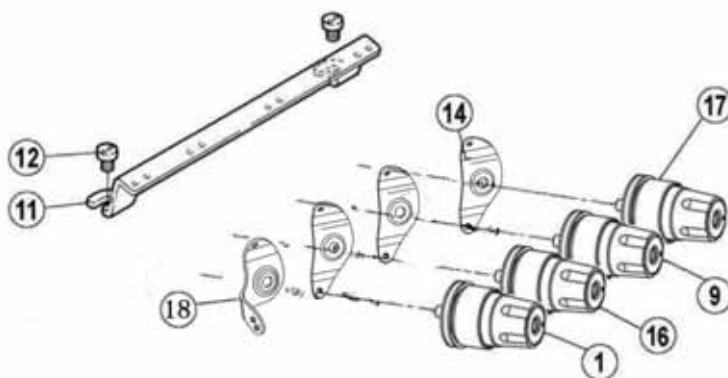

五、夹线部件/Thread Tension Mechanism

序号 NO.	公司件号 Part NO.	参考件号 Ref. Part No.	名称	Description	数量 (Number)		
					三线 three-thread	四线 four-thread	五线 five-thread
1	400662	210529-9U	夹线器组件 (红点)	Tension Spring Assembly	1	1	1
2	301S16006	208447-UA	调压螺母	Knob	1	1	1
3	30111006	208448	调压止动套	Ratchet	1	1	1
4	30111005	208450-UA	调压止动盖	Cup	1	1	1
5	400161	210319	夹线片	Tension Disc	2	2	2
6	20623008	208449	夹线片垫	Felt	1	1	1
7	201S30016	5082A	夹线螺钉	Screw Stud	1	1	1
8	30127011	20137	调压簧	Spring	1	2	2
9	400663	210531-9U	夹线器组件 (蓝点)	Tension Spring Assembly	1	1	1
10	30127012	201086	调压簧 (中)	Spring	1	1	1
11	20713001	27500	过线板	Thread Guide	1	1	1
12	207S11007	7019	螺钉M4×7.5	Screw	2	2	2
14	20113002	202849	过线板	Tension Guide	3	3	3
15	206S11005	4009-HC	螺钉SM11/64×40	Screw	1	0	0
16	400661	210530-9U	夹线器组件 (黄点)	Tension Spring Assembly	0	1	1
17	400668	210532-9U	夹线器组件 (绿点)	Tension Spring Assembly	1	1	1
18	20712032		过线板	Thread Guide	0	1	1
19	30127013		调压簧 (弱)	Spring	1	1	1

5 Series

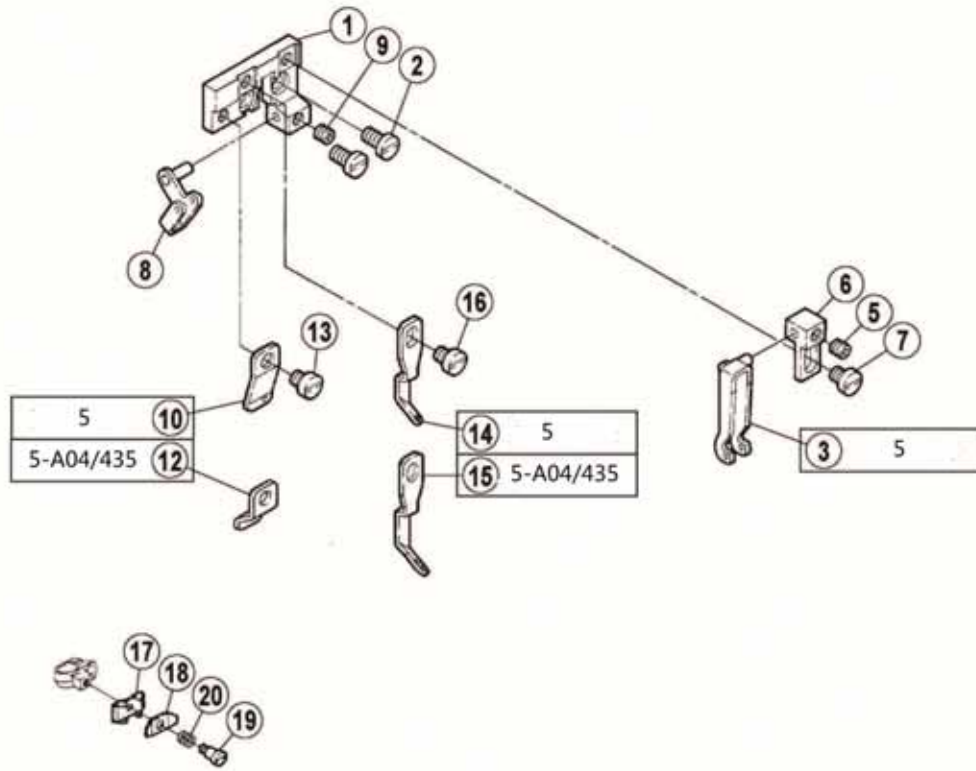

5 Series

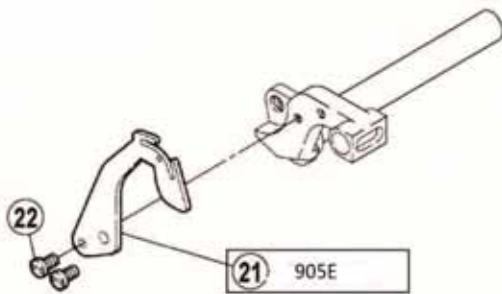

5-A04/435 Series

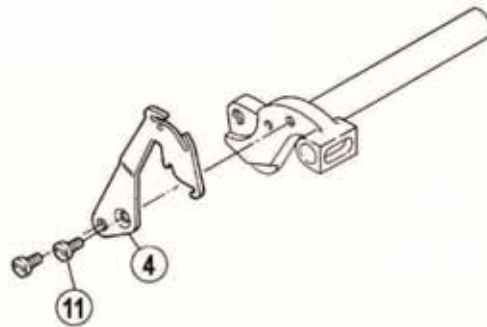

六、过线机构(1)/Thread Guide and Thread Takeup(1)

序号 NO.	公司件号 Part NO.	参考件号 Ref.Part No.	名称	Description	数量 (Number)		
					三线 three-thread	四线 four-thread	五线 five-thread
1	20701029	275021	托架	Bracket	0	0	1
2	207S11019	7082	螺钉M4×7.5	Screw	0	0	2
3	20713020	275024	过线	Thread Guide	0	0	1
4	20713052	275049	挑线杆	Thread Takeup	0	0	1
5	207S14001	4543	螺钉M4×4	Screw	0	0	1
6	20701030	275026	托架	Bracket	0	0	1
7	S01031	7017	螺钉M4×4.7	Screw	0	0	1
8	20713021	275022	过线	Thread Guide	0	0	1
9	207S14001	4543	螺钉M4×4	Screw	0	0	1
10	20713022	275029	过线	Thread Guide	0	0	1
11	207S11015	7062	螺钉M3×6	Screw	0	0	2
12	20713050	275052	过线	Thread Guide	0	0	1
13	S01031	7017	螺钉M4×4.7	Screw	0	0	1
14	20713023	275028	过线	Thread Guide	0	0	1
15	20713051	275057	过线	Thread Guide	0	0	1
16	S01031	7017	螺钉M4×4.7	Screw	0	0	1
17	20713006	275011	托架	Bracket	0	0	1
18	20713007	275012	压线板	Thread Retainer	0	0	1
19	207S20003	7163	螺钉	Screw	0	0	1
20	20727002	240326	压簧	Spring	0	0	1
21	20713024	275027	挑线杆	Thread Takeup	0	0	1
22	207S11015	7062	螺钉M3×6	Screw	0	0	2

3/4 Series

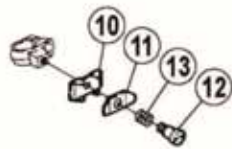
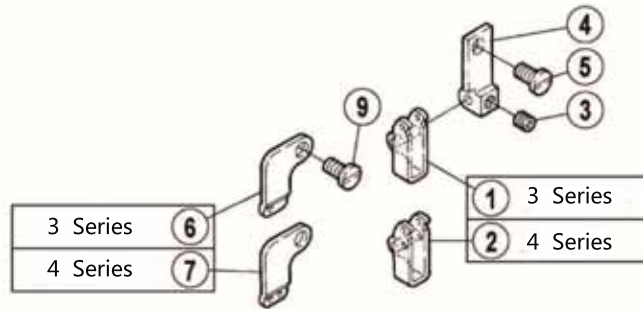

3/4 Series

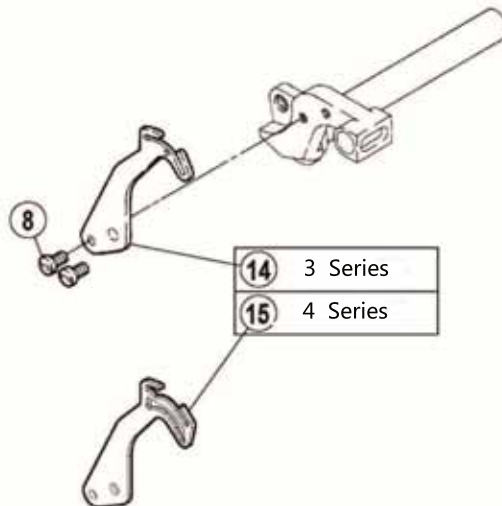

七、过线机构(2)/Thread Guide and Thread Takeup(2)

序号 NO.	公司件号 Part NO.	参考件号 Ref.Part No.	名称	Description	数量 (Number)		
					三线 three-thread	四线 four-thread	五线 five-thread
1	20713002	275013A	过线	Thread Guide	1	0	0
2	20713003	275013	过线	Thread Guide	0	1	0
3	207S14001	4543	螺钉M4 × 4	Screw	1	1	0
4	20701010	275015	托架	Bracket	1	1	0
5	207S11019	7082	螺钉M4 × 4.7	Screw	1	1	0
6	20713004	275051	过线	Thread Guide	1	0	0
7	20713005	275051A	过线	Thread Guide	0	1	0
8	207S11015	7062	螺钉M3 × 6	Screw	2	2	0
9	207S11019	7082	螺钉M4 × 7.5	Screw	1	1	0
10	20713006	275011	托架	Bracket	1	1	0
11	20713007	275012	压线板	Thread Retainer	1	1	0
12	207S20003	7163	螺钉	Screw	1	1	0
13	20727002	240326	压簧	Spring	1	1	0
14	20713008	275016	挑线杆	Thread Takeup	1	0	0
15	20713009	275016	挑线杆	Thread Takeup	0	1	0

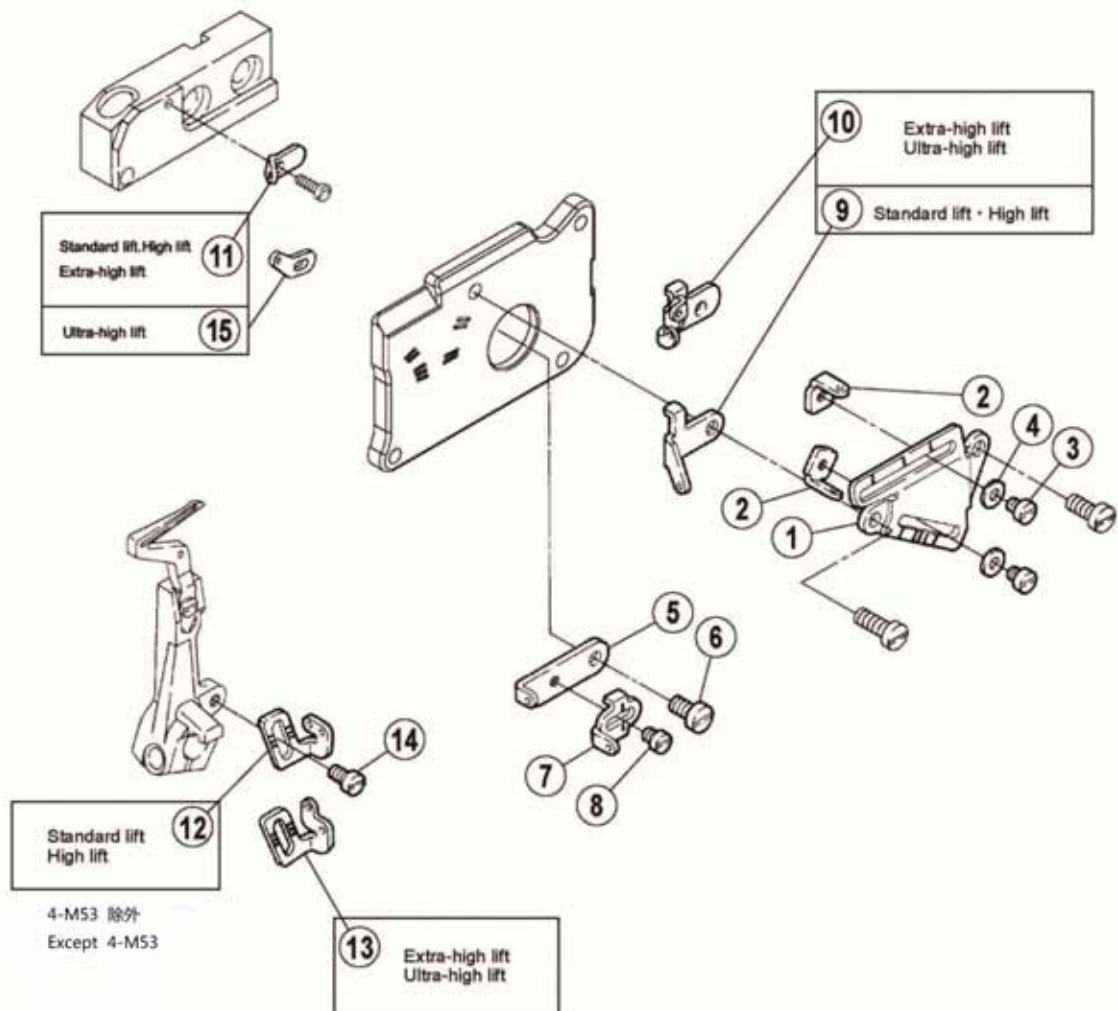

八、过线机构(3)/Thread Guide and Thread Takeup(3)

序号 NO.	公司件号 Part NO.	参考件号 Ref.Part No.	名称	Description	数量 (Number)		
					三线 three-thread	四线 four-thread	五线 five-thread
1	20712016	275004	托架	Bracket	1	1	1
2	20113015	275047	过线	Thread Guide	2	2	2
3	201S11006	----	螺钉	Screw	2	2	2
4	W01011	----	垫圈	Washer	2	2	2
5	20713010	275005	挑线架	Thread Takeup	1	1	1
6	207S11007	7019	螺钉M4×7.5	Screw	1	1	1
7	20713011	275006	过线	Thread Guide	1	1	1
8	207S11020	7008	螺钉M3×4	Screw	1	1	1
9	20713012	275007	过线	Thread Guide	1	1	0
10	20713053	275055	过线	Thread Guide	0	0	1
11	20713054	275056	过线	Thread Guide	0	0	1
12	20713015	275009	挑线架	Thread Takeup	1	1	0
13	20713055	275054	挑线架	Thread Takeup	0	0	1
14	207S11021	7012	螺钉M3.5×6	Screw	1	1	1
15	20713013	275010	过线	Thread Guide	1	1	1

5 Series
3/4 Series

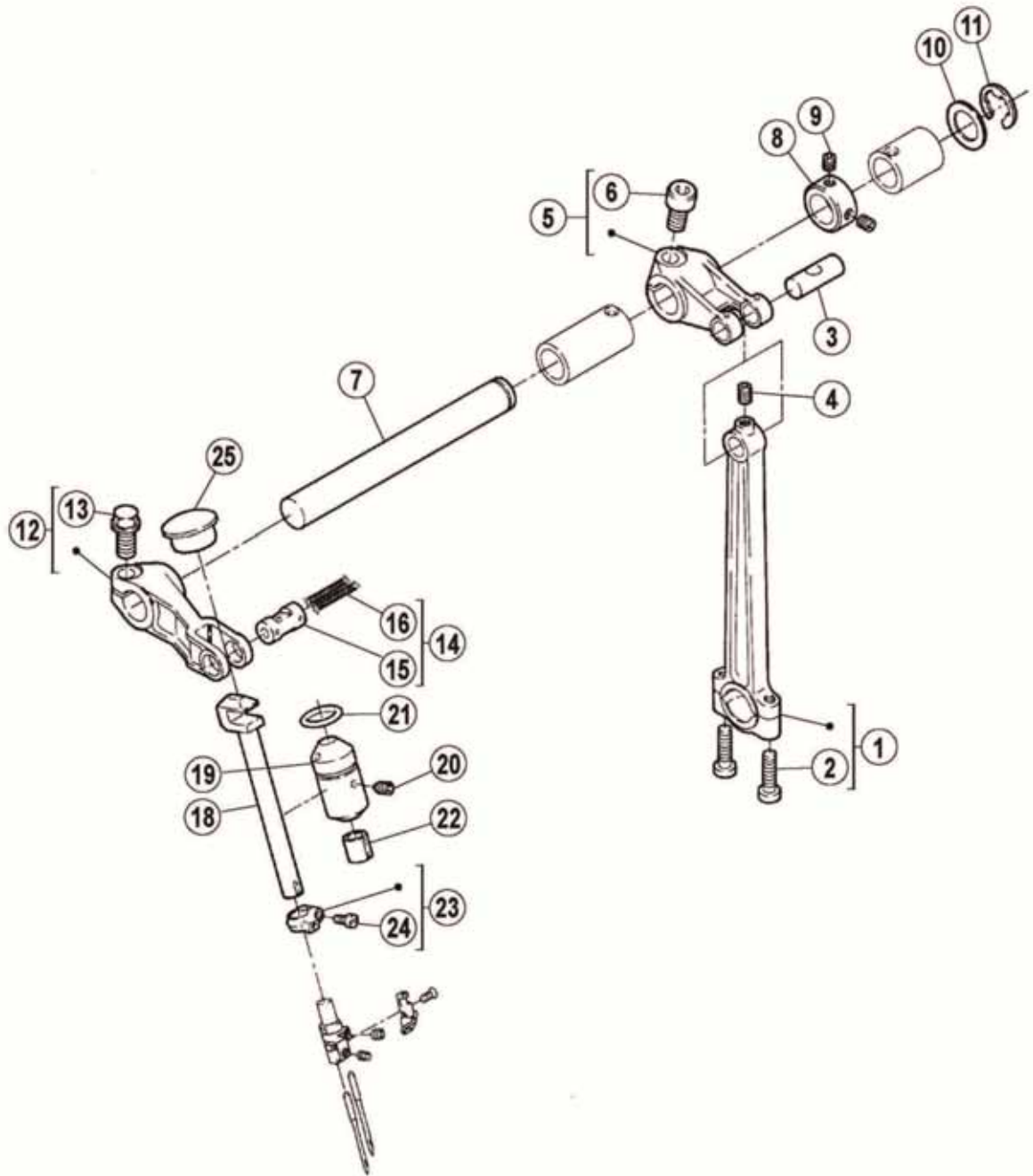

九、针杆部件(1)/Needle Drive Mechanism(1)

序号 NO.	公司件号 Part NO.	参考件号 Ref.Part No.	名称	Description	数量 (Number)		
					三线 three-thread	四线 four-thread	五线 five-thread
1	400039	271000-92	针杆连杆	Connection	1	1	1
2	207S11016	7023	螺钉M4 × 16	Screw	2	2	2
3	20626003	271001	曲柄销	Pin	1	1	1
4	207S14007	4538	螺钉M4 × 6	Screw	1	1	1
5	20704001	271002-92	上轴曲柄	Crank	1	1	1
6	S05018	4533	螺钉M6 × 0.75 × 12	Screw	1	1	1
7	20702002	271003	上轴	Shaft	1	1	1
8	20708004	240308	上轴挡圈	Collar	1	1	1
9	207S14001	4543	螺钉M4 × 4	Screw	2	2	2
10	20628014	208235	上刀架垫片	Washer	1	1	1
11	H05008	202577	挡圈8	Ring	1	1	1
12	20704002	271004-92	针杆曲柄组件	Lever	1	1	1
13	207S12002	7150	螺钉	Screw	1	1	1
14	2072600300	271022-91	曲柄销组件	Shaft Assembly	1	1	1
15	20726003	271008-T	曲柄销	Shaft	1	1	1
16	20523005	----	油线	Oil wick	1	1	1
18	20702003	271006-T	针杆	Needle Bar	1	1	1
19	20703012	271007	针杆套	Bushing	1	1	1
20	207S14008	4546	螺钉M4 × 5	Screw	1	1	1
21	001026	201022	O型圈11.5 × 1.5	O Ring	1	1	1
22	20723003	179009-05	毛毡	Oil Felt	1	1	1
23	20708005	271009-92	挡圈	Ring	1	1	1
24	207S11023	7035	螺钉M3 × 6	Screw	1	1	1
25	20722004	240310	油塞	Plug	1	1	1

5 Series

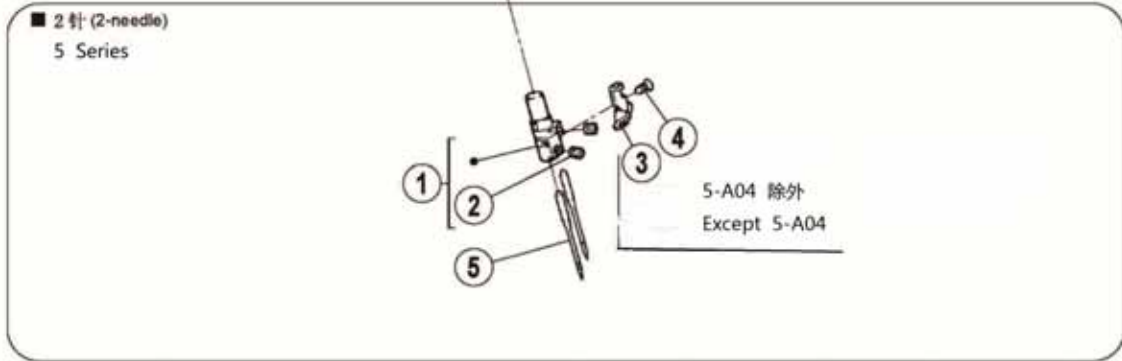

3/4 Series

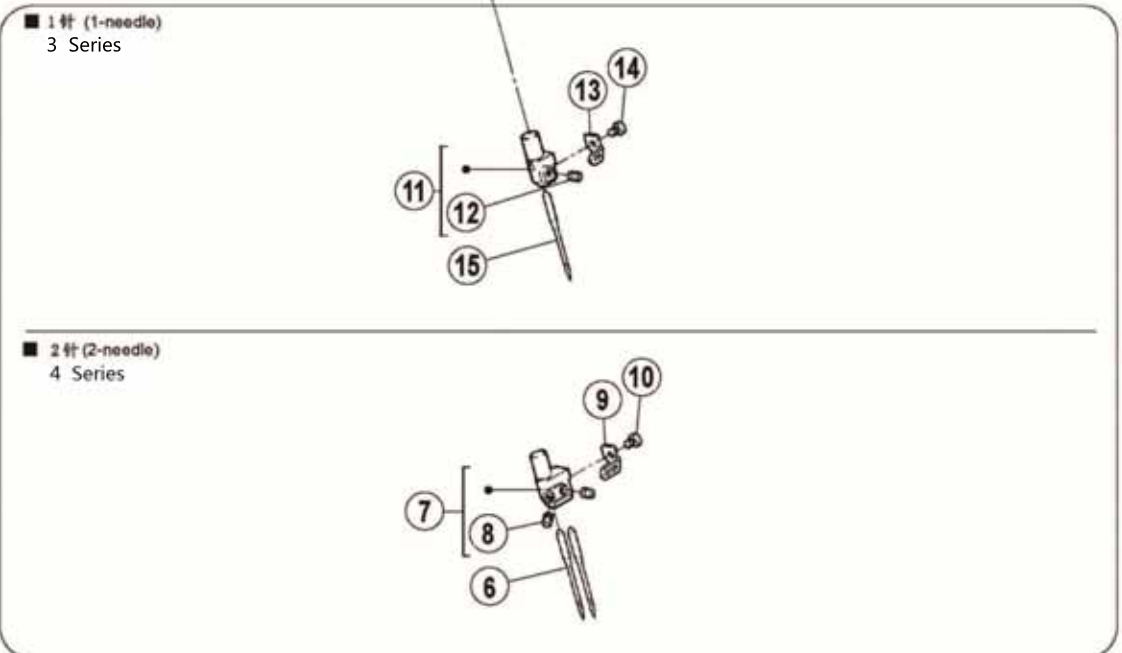

十、针杆部件(2)/Needle Drive Mechanism(2)

序号 NO.	公司件号 Part NO.	参考件号 Ref.Part No.	名称	Description	数量 (Number)		
					三线 three-thread	四线 four-thread	五线 five-thread
1	20734003	xxxxxxx	针夹头	Needle Holder Assembly	0	0	1
1	20734004	xxxxxxx	针夹头 (五线70)	Needle Holder Assembly	0	0	1
1	20719056	xxxxxxx	针夹头 (五线厚料)	Needle Holder Assembly	0	0	1
2	207S14014	4554	螺钉M3×3	Screw	0	0	2
3	20713017	275030	过线	Thread Guide	0	0	1
4	207S11024	7120	螺钉M2×3	Screw	0	0	1
5	xxxxxxx	xxxxxxx	机针	Needle	0	0	2
6	xxxxxxx	xxxxxxx	机针	Needle	0	2	0
7	20734002	xxxxxxx	(四线)针夹头	Needle Holder	0	1	0
8	207S14014	4554	螺钉M3×3	Screw	0	2	0
9	20713018	275019C	过线	Thread Guide	0	1	0
10	207S11024	7120	螺钉M2×3	Screw	0	1	0
11	20734001	xxxxxxx	(三线)针夹头	Needle Holder Assembly	1	0	0
12	207S14014	4554	螺钉M3×3	Screw	1	0	0
13	20713038	275019A	过线(一针)	Thread Guide	1	0	0
14	207S11024	7120	螺钉M2×3	Screw	1	0	0
15	xxxxxxx	xxxxxxx	机针	Needle	1	0	0

5 Series

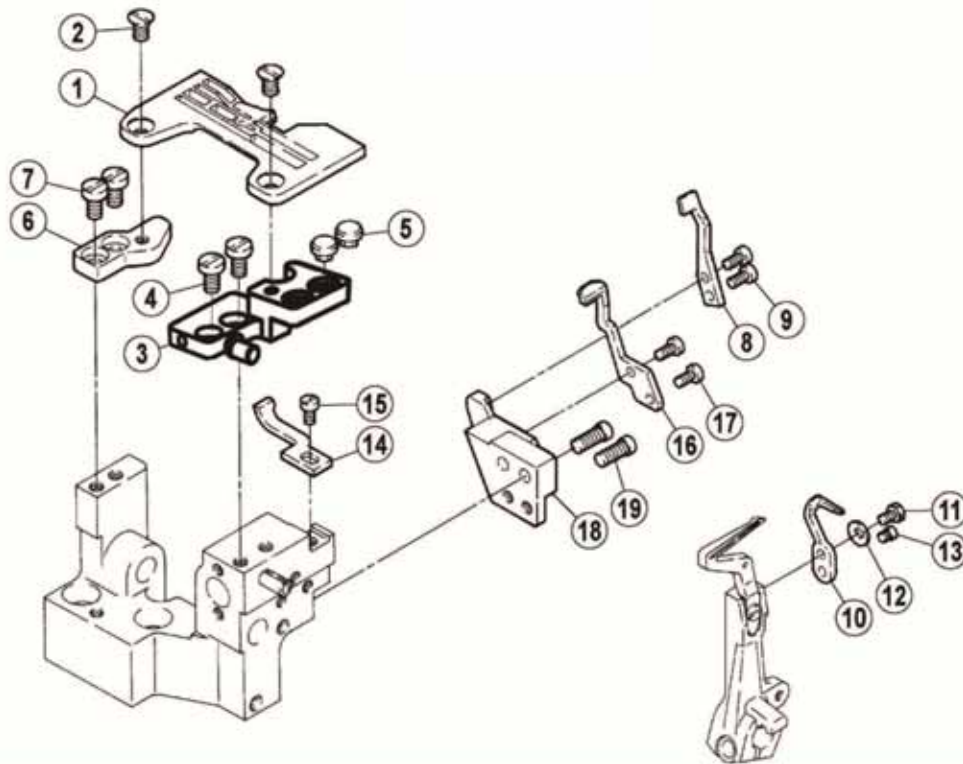

3/4 Series

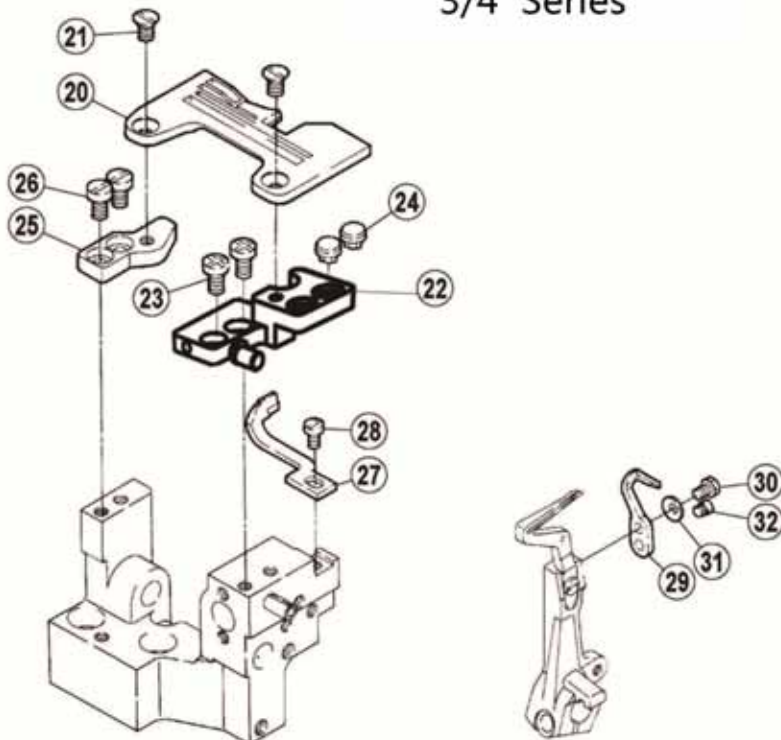

十一、针杆部件(3)/Needle Drive Mechanism(3)

序号 NO.	公司件号 Part NO.	参考件号 Ref.Part No.	名称	Description	数量 (Number)		
					三线 three-thread	四线 four-thread	五线 five-thread
1	xxxxxxx	xxxxxxx	针板	Needle Plate	0	0	1
2	207S17006	7170	螺钉M4×7.5	Screw	0	0	2
3	20709002	271010	针板垫块(前)	Bracket	0	0	1
4	207S11007	7019	螺钉M4×7.5	Screw	0	0	2
5	20622003	240305	防震垫	Cushion Rubber	0	0	2
6	20709003	271011	针板垫块(后)	Bracket	0	0	1
7	207S11007	7019	螺钉M4×7.5	Screw	0	0	2
8	xxxxxxx	xxxxxxx	链弯针护针	Needle Guard	0	0	1
9	S01027	7010	螺钉M3×6	Screw	0	0	2
10	xxxxxxx	xxxxxxx	护针(后)	Needle Guard	0	0	1
11	207S12005	7259	螺钉	Screw	0	0	1
12	W03004	240222	垫圈3	Spring	0	0	1
13	207S11002	7165	螺钉M3	Screw	0	0	1
14	xxxxxxx	xxxxxxx	机针护针(前)	Needle Guard	0	0	1
15	207S11007	7019	螺钉M4×7.5	Screw	0	0	1
16	xxxxxxx	xxxxxxx	机针护针(后)	Needle Guard	0	0	1
17	S01027	7010	螺钉M3×6	Screw	0	0	2
18	20701033	271013	托架	Bracket	0	0	1
19	207S11003	7114	螺钉M4×10	Screw	0	0	2
20	xxxxxxx	xxxxxxx	针板	Needle Plate	0	1	0
21	207S17006	7170	螺钉M4×7.5	Screw	2	2	0
22	20709002	271010	针板垫块(前)	Bracket	1	1	0
23	207S11011	xxxxxxx	螺钉M4×7.5	Screw	2	2	0
24	20622003	240305	减震垫	Cushion Rubber	2	2	0
25	20709003	271011	针板垫块(后)	Bracket	1	1	0
26	207S11007	7019	螺钉M4×7.5	Screw	2	2	0
27	xxxxxxx	xxxxxxx	护针(前)	Needle Guard	1	1	0
28	207S11007	7019	螺钉M4×7.5	Screw	1	1	0
29	xxxxxxx	xxxxxxx	护针(后)	Needle Guard	1	1	0
30	207S12005	7259	螺钉	Screw	1	1	0
31	W03004	240222	垫圈3	Spring	1	1	0
32	207S11002	7165	螺钉M3	Screw	1	1	0

5 Series 3/4 Series

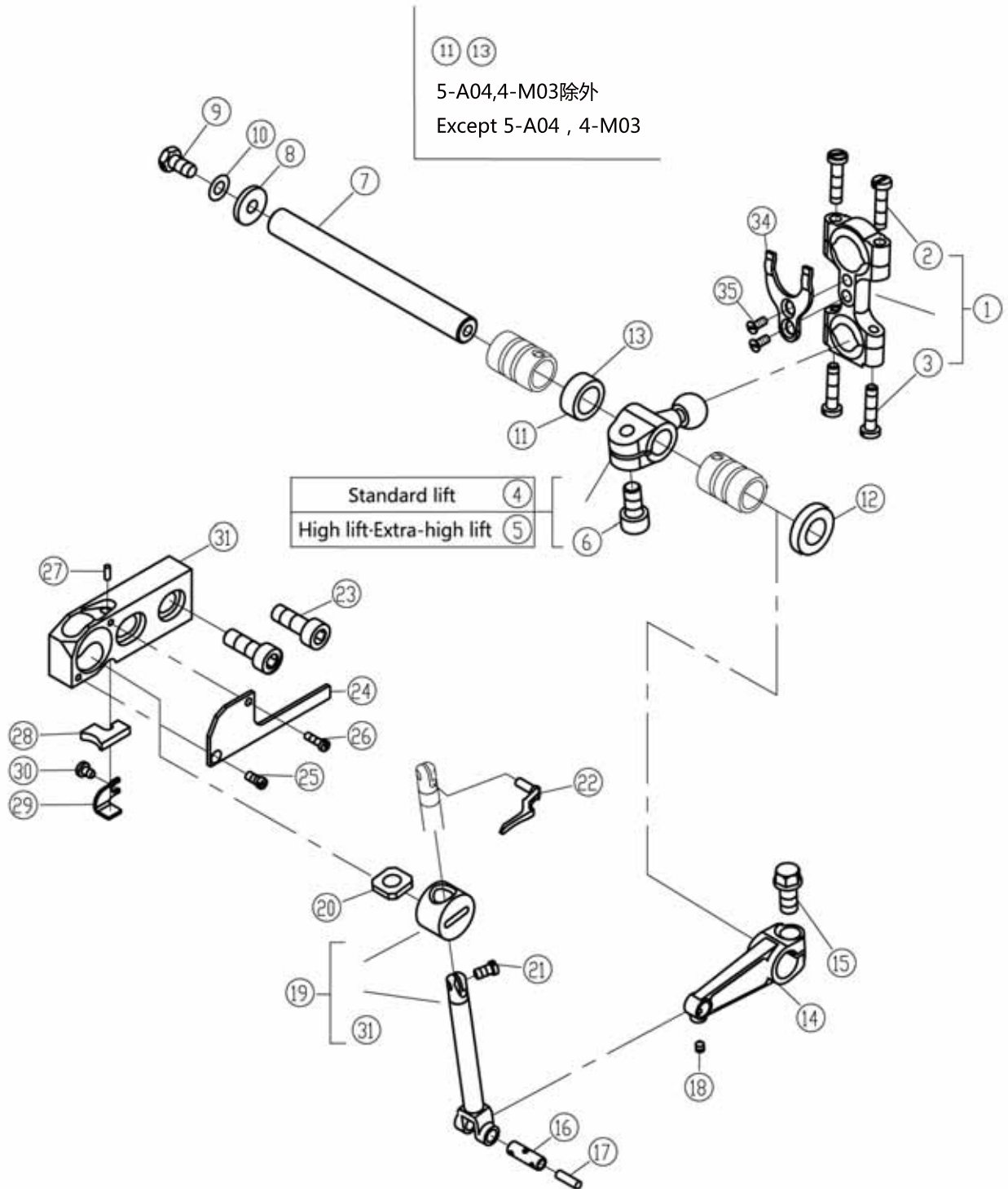

十二、上弯针部件/Upper Looper Drive Mechanism

序号 NO.	公司件号 Part NO.	参考件号 Ref.Part No.	名称	Description	数量 (Number)		
					三线 three-thread	四线 four-thread	五线 five-thread
1	400043	271500-92	弯针连杆	Connection	1	1	1
2	207S11016	7023	螺钉M4 × 16	Screw	2	2	2
3	207S11005	7022	螺钉M4 × 17.5	Screw	2	2	2
4	20704003	271502-92	上弯针球曲柄	Crank	1	0	0
5	400037	271503-92	上弯针球曲柄	Crank	0	1	1
6	S05018	4533	螺钉M6 × 0.75 × 12	Screw	1	1	1
7	20702004	271504	下弯针轴	Shaft	1	1	1
8	20628006	240338	垫圈	Washer	1	1	1
9	207S11004	7174	螺钉M4 × 10	Screw	1	1	1
10	W02001	303067	上弯针垫圈	Spring Washer	1	1	1
11	20708006	210122	衬套	Spacer	0	1	0
12	20622019	210586A	油封	Oil Seal	1	1	1
13	20708007	210122A	衬套A	Spacer	1	0	1
14	20705003	271505-92	连杆	Lever	1	1	1
15	207S12002	7150	螺钉	Screw	1	1	1
16	20726004	179137-05	曲柄销	Pin Assy.	1	1	1
17	20523005	----	JK788油线	Oil Weak	1	1	1
18	207S14010	4545	螺钉M3 × 4	Screw	1	1	1
19	2070403400	271517-91	上弯针滑杆组件	Upper Looper Holder Assy	1	1	1
20	20623005	179130-05	上弯针滑杆套油毡	Felt	1	1	1
21	207S11025	7054	螺钉M3.5 × 6.7	Screw	1	1	1
22	xxxxxxxx	xxxxxxxx	上弯针	Upper Looper	1	1	1
23	207S11026	4510	螺钉M6 × 16	Screw	2	2	2
24	400040	xxxxxxxx	盖板	Cover	1	1	1
25	207S17004	xxxxxxxx	螺钉M2.5 × 6	Screw	1	1	1
26	207S11027	7033	螺钉M2.5 × 8	Cover	1	1	1
27	20123021	----	JK795油线	Oil Wick	1	1	1
28	20723005	2745890	吸油棉	Felt	1	1	1
29	20712017	2745880	压板	Bracket	1	1	1
30	207S11020	7008	螺钉M3 × 4	Screw	1	1	1
31	20701051	271510B	上弯针滑块座	Upper Looper Bracket	1	1	1
34	20712066	----	连杆垫片	Washer	1	1	1
35	S02007	----	螺钉	Screw	2	2	2

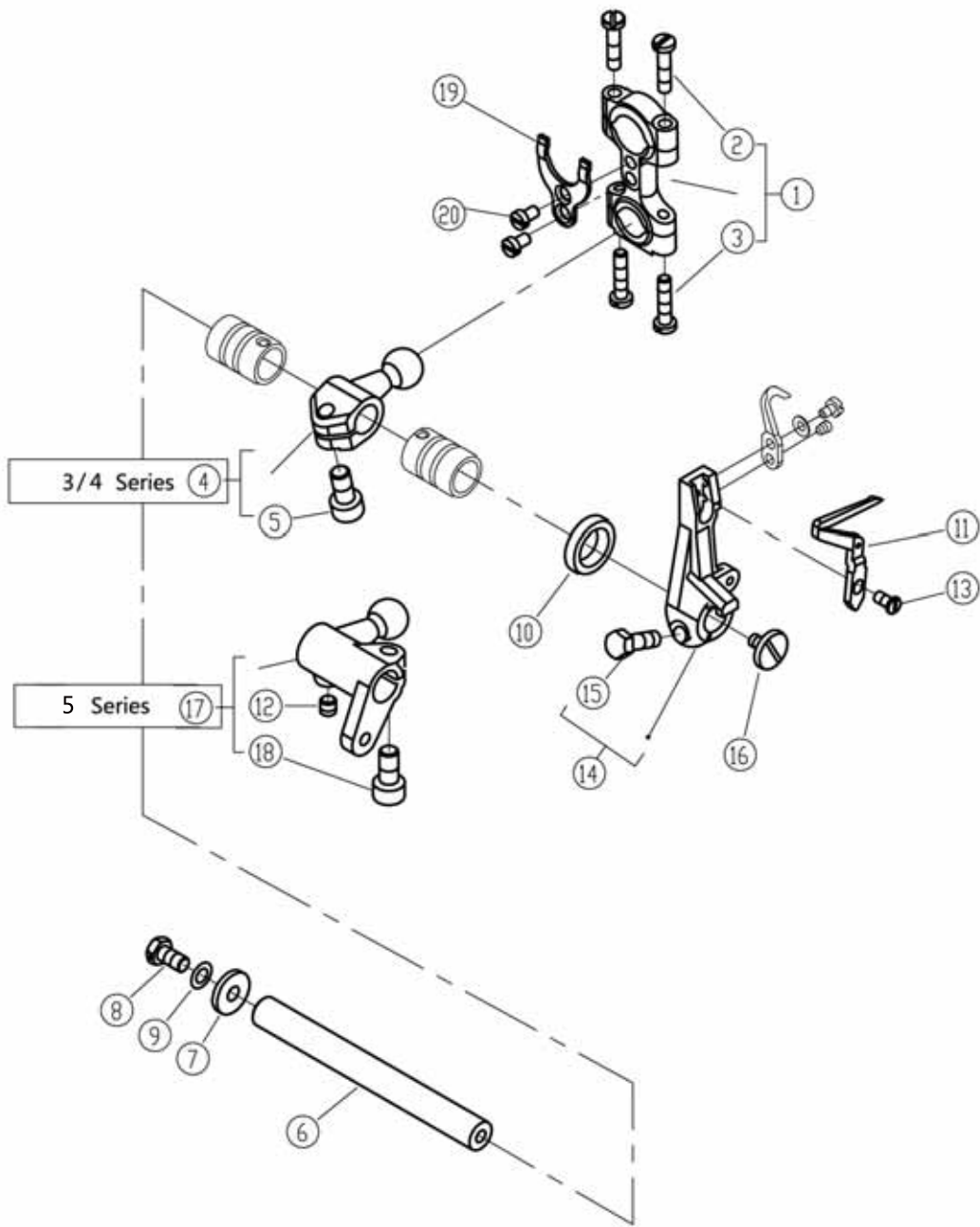

十三、下弯针部件/Lower Looper Drive Mechanism

序号 NO.	公司件号 Part NO.	名称	Description	数量 (Number)		
				三线 three-thread	四线 four-thread	五线 five-thread
1	400043	弯针连杆	Connection	1	1	1
2	207S11016	螺钉M4 × 16	Screw	2	2	2
3	207S11005	螺钉M4 × 17.5	Screw	2	2	2
4	400329	下弯针球曲柄	Crank	1	1	0
5	S05018	螺钉M6 × 0.75 × 12	Screw	1	1	0
6	20702004	下弯针轴	Shaft	1	1	1
7	20628006	垫圈	Washer	1	1	1
8	207S11004	螺钉M4 × 10	Screw	1	1	1
9	W02001	上弯针垫圈	Spring Washer	1	1	1
10	20622019	油封	Oil Seal	1	1	1
11	xxxxxxx	下弯针	Lower Looper	1	1	1
12	207S14006	螺钉M5 × 5	Screw	0	0	1
13	207S11028	螺钉M3.5 × 6.5	Screw	1	1	1
14	20704007	下弯针架	Lower Looper Holder	1	1	1
15	207S20004	螺钉M5 × 13	Screw	1	1	1
16	207S15001	螺钉M4 × 7	Screw	1	1	1
17	400388	下弯针球曲柄	Crank	0	0	1
18	S05018	螺钉M6 × 0.75 × 12	Screw	0	0	1
19	20712066	连杆垫片	Washer	1	1	1
20	S02007	螺钉	Screw	2	2	2

5 Series

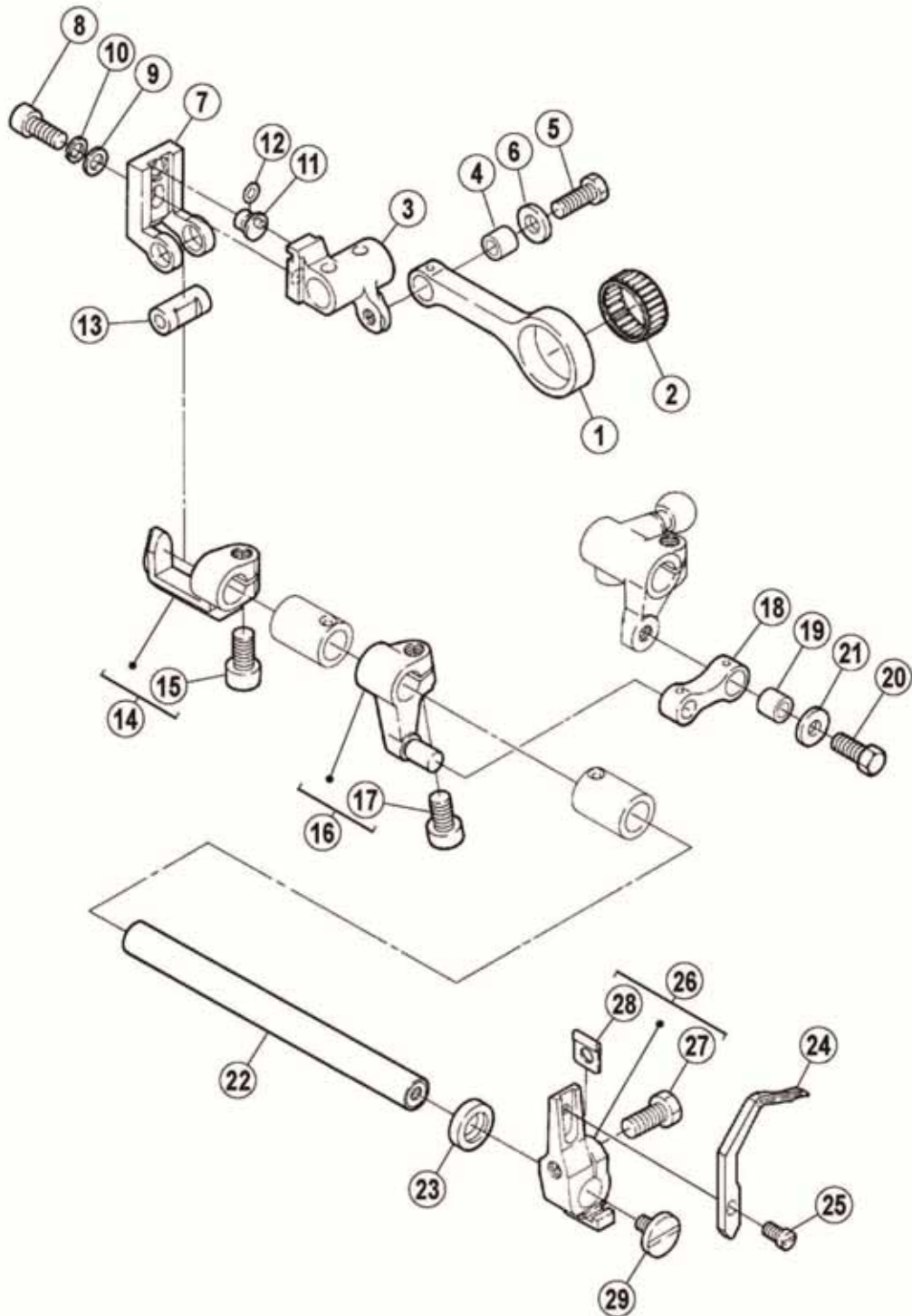

十四、二重环弯针机构(1)/Chainstitch Looper Drive Mechanism(1)

序号 NO.	公司件号 Part NO.	参考件号 Ref.Part No.	名称	Description	数量 (Number)		
					三线 three-thread	四线 four-thread	五线 five-thread
1	20705006	273500	连杆	Connection	0	0	1
2	B08002	205015	滚针k22 × 18 × 8	Needle Bearing	0	0	1
3	20704014	273501	曲柄	Crank	0	0	1
4	20703016	179160-05	连杆套	Bushing	0	0	1
5	207S12003	7056	螺钉M5 × 13	Screw	0	0	1
6	30228008	204115	垫圈	Washer	0	0	1
7	20709017	273502	滑块座	Slider	0	0	1
8	207S13009	4531	螺钉M5 × 12	Screw	0	0	1
9	20628010	240062	送布曲柄销垫圈	Washer	0	0	1
10	W02001	303067	上弯针垫圈	Spring Washer	0	0	1
11	20710008	252515	偏心销	Pin	0	0	1
12	001027	208949	O型圈4 × 1.3	O Ring	0	0	1
13	20626017	273504	五线销	Shaft	0	0	1
14	20701034	273505-92	支架	Holder	0	0	1
15	S05018	4533	螺钉M6 × 0.75 × 12	Screw	0	0	1
16	20704015	273509-92	链线曲柄	Crank	0	0	1
17	S05018	4533	螺钉M6 × 0.75 × 12	Screw	0	0	1
18	20705008	272517	连杆	Link	0	0	1
19	20703016	179160-05	连杆套	Bushing	0	0	1
20	207S12003	7056	螺钉M5 × 13	Screw	0	0	1
21	30228008	204115	垫圈	Washer	0	0	1
22	20702018	273506	链线轴	Shaft	0	0	1
23	3052201700	204052A	油封	Oil Seal	0	0	1
24	xxxxxxxx	xxxxxxxx	弯针	Double Chainstith Looper	0	0	1
25	207S11028	7168	螺钉M3.5 × 6.5	Screw	0	0	1
26	20701035	273510-92	弯针架	Looper Holder	0	0	1
27	207S20004	7055	螺钉M5 × 13	Screw	0	0	1
28	20728002	240337	垫片	Spacer	0	0	1
29	207S15001	7169	螺钉M4 × 7	Screw	0	0	1

5 Series

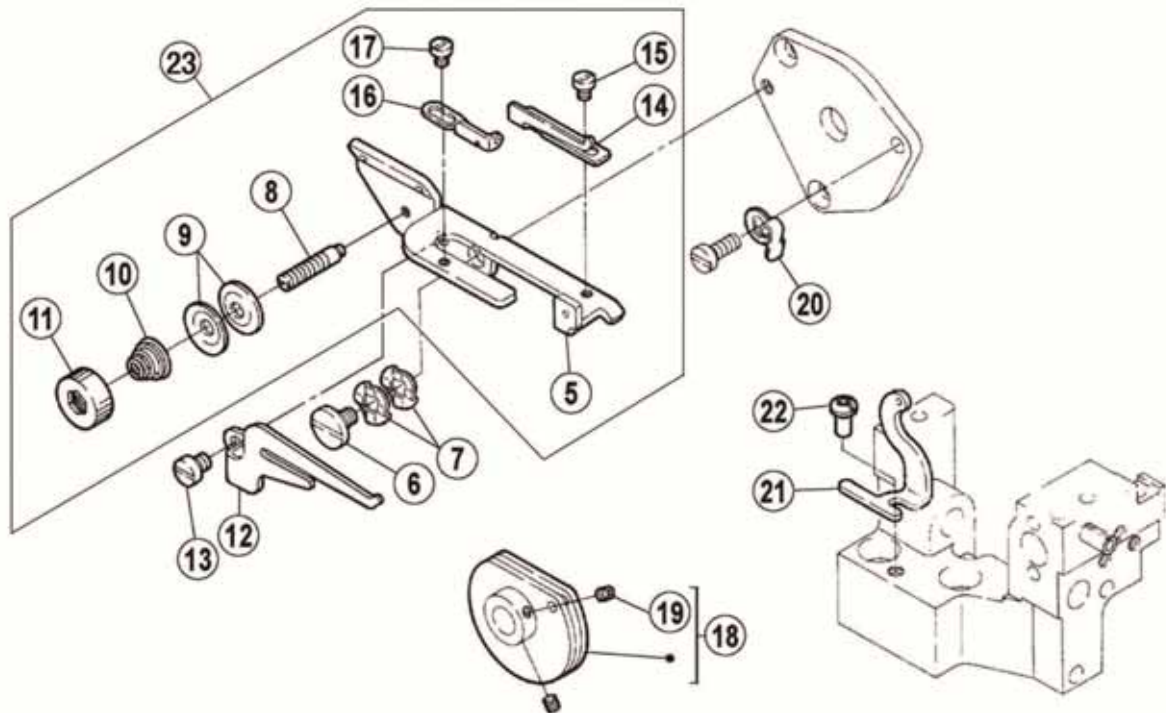
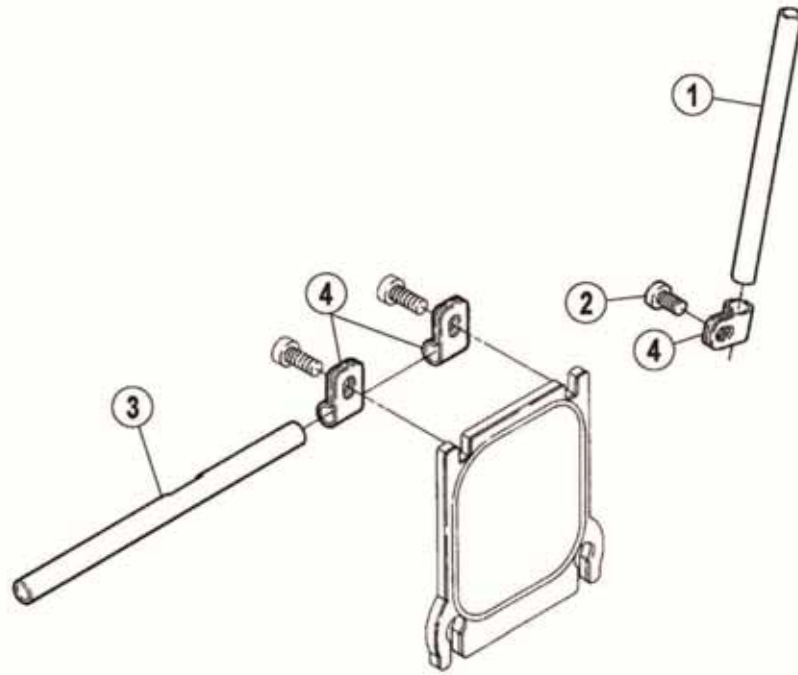

十五、二重环弯针机构(2)/Chainstitch Looper Drive Mechanism(2)

序号 NO.	公司件号 Part NO.	参考件号 Ref.Part No.	名称	Description	数量 (Number)		
					三线 three-thread	四线 four-thread	五线 five-thread
1	20713063	1921200	过线管	Thread Guide	0	0	1
2	207S11007	7019	螺钉M4×7.5	Screw	0	0	1
3	20713040	275032	过线管	Thread Guide	0	0	1
4	20629003	206115	过线管夹	Holder	0	0	3
5	2061205700	275033	打线凸轮组件	Looper Thread Takeup Assy	0	0	1
6	207S20002	7066	螺钉M4	Screw	0	0	1
7	20128015	210307	垫圈	Washer	0	0	1
8	206S30015	7167	螺钉M3	Screw	0	0	1
9	20612055	137108	夹线片	Tension Disc	0	0	2
10	30127016	211388	弹簧	Spring	0	0	1
11	206S16004	275034	紧线手柄	Knob	0	0	1
12	20612056	275035	分线板	Thread Guide	0	0	1
13	S01031	7017	螺钉M4×7.5	Screw	0	0	1
14	20629004	275036	过线	Thread Guide	0	0	1
15	207S11020	7008	螺钉M3×4	Screw	0	0	1
16	20613017	275039	过线	Thread Guide	0	0	1
17	207S11020	7008	螺钉M3×4	Screw	0	0	1
18	20612058	179498-92	打线凸轮	Looper Thread Takeup	0	0	1
19	207S14009	4554	螺钉M3×3	Screw	0	0	2
20	20629005	275037	卡簧	Spring	0	0	1
21	20713026	275038	过线	Tread Guide	0	0	1
22	207S11007	7019	螺钉M4×7.5	Screw	0	0	1
23	2061205700	275033	打线凸轮组件	Looper Thread Takeup Assy	0	0	1

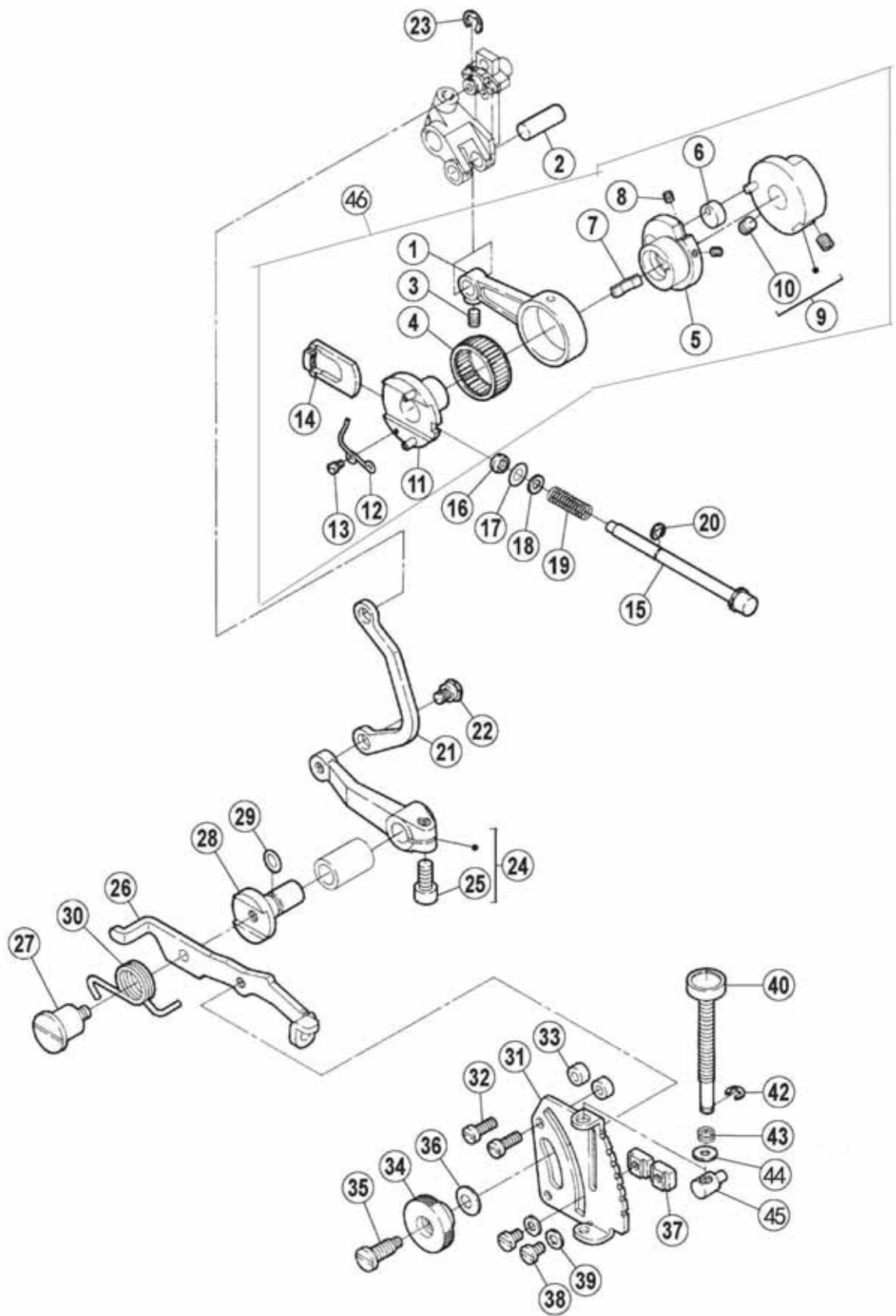

十六、差动调节机构/Feed Mechanism

序号 NO.	公司件号 Part NO.	参考件号 Ref.Part No.	名称	Description	数量 (Number)		
					三线 three-thread	四线 four-thread	五线 five-thread
1	20705004	272500	送料连杆	Connection	1	1	1
2	20626003	271001	曲柄销	Pin	1	1	1
3	207S14007	4538	螺钉M4×6	Screw	1	1	1
4	B08001	240012	滚针轴承26×22×10	Needle Bearing	1	1	1
5	20710001	272501	偏心轮	Eccent	1	1	1
6	20710002	210129	小偏心轮	Feed Eccent	1	1	1
7	20712018	210130	弹簧板	Flat Spring	1	1	1
8	207S14003	4535	螺钉M3×4	Screw	2	2	2
9	20710003	272506-91	送布偏心	Regulator	1	1	1
10	207S14012	4514	螺钉M5×5	Screw	2	2	2
11	20710004	272504-91	开针偏心凸轮	Eccent Assembly	1	1	1
12	20727003	272503	弹簧	Spring	1	1	1
13	207S20005	7038	螺钉M2	Screw	1	1	1
14	20709006	272502	滑块	Ratchet	1	1	1
15	20702005	272509	开针掀扭轴	Push Button	1	1	1
16	20722005	240315	油封	Gaket	1	1	1
17	001027	208949	O型圈4×1.3	O Ring	1	1	1
18	20728001	240314	垫片	Washer	1	1	1
19	20727004	240317	弹簧	Spring	1	1	1
20	H05018	200555	卡簧3.5	Ring	1	1	1
21	20705005	272529	差动连片	Link	1	1	1
22	207S20006	7058	螺钉M5×5	Screw	1	1	1
23	20629006	202522	卡簧	Ring	1	1	1
24	20704008	272530A92	差动曲柄	Lever	1	1	1
25	S05018	4533	螺钉M6×0.75×12	Screw	1	1	1
26	20712019	272532	差动杆	Lever	1	1	1
27	207S20007	7161	螺钉	Screw	1	1	1
28	20702006	272533A	差动轴	Shaft	1	1	1
29	20622010	204185	差动轴O型圈	O Ring	1	1	1
30	20627006	272534	差动扳手定位簧	Spring	1	1	1
31	20712020	272535	调节板	Regulator Plate	1	1	1
32	207S11008	7021	螺钉M4×12	Screw	2	2	2
33	20711007	240321	垫圈	Spacer	2	2	2
34	2071600100	179202-25	调节螺母	Nut	1	1	1
35	207S30001	179202-25-02	螺钉	Screw	1	1	1
36	20728003	7059	蝶形垫片	Spring Washer	1	1	1
37	207S16002	211301	螺母	Stopper	2	2	2
38	207S11011	252658	螺钉M4×5	Screw	2	2	2
39	30228009	7018	垫片	Washer	2	2	2
40	20702007	303448	调节杆	Adjusting Bar	1	1	1
42	H05018	240322	卡簧3.5	Ring	1	1	1
43	20727005	210533	弹簧	Spring	1	1	1
44	20728005	----	垫片	Washer	1	1	1
45	20709007	272539A	螺母	Pin	1	1	1
46	2070500400	----	送料连杆组件	Connect ion	1	1	1

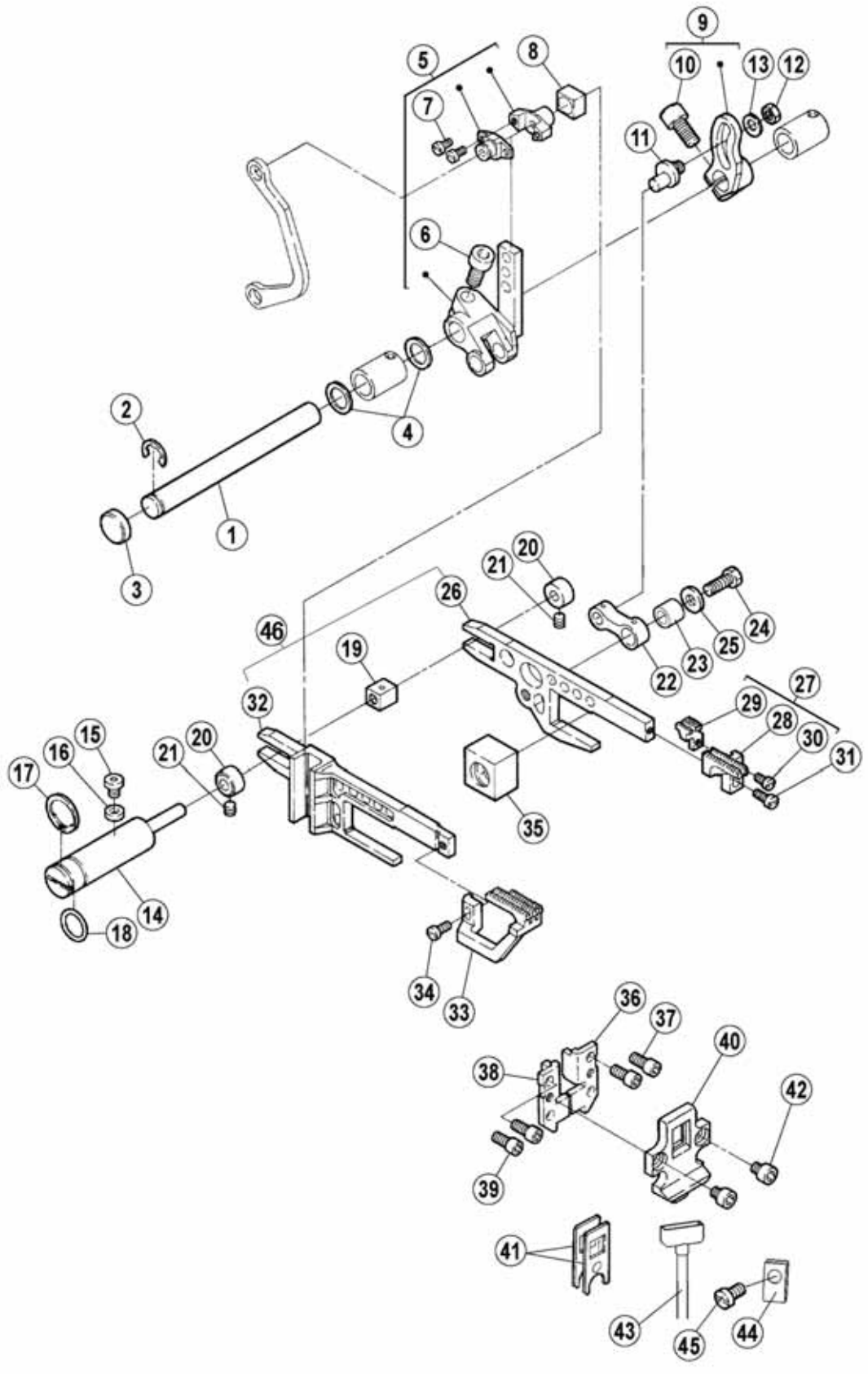

十七、送布机构/Feed Mechanism

序号 NO.	公司件号 Part NO.	参考件号 Ref.Part No.	名称	Description	数量 (Number)		
					三线 three-thread	四线 four-thread	五线 five-thread
1	20702008	272516	送布轴	Shaft	1	1	1
2	H05009	205061	开口挡圈7	Ring	1	1	1
3	20628023	208173	送布轴油封	Plug	1	1	1
4	20628011	240311	送料轴垫圈	Washer	2	2	2
5	2070400900	272510-91	送料曲柄组件	Crank	1	1	1
6	207S13005	4534	螺钉M6 × 14	Screw	1	1	1
7	207S11029	7010	螺钉M3 × 6	Screw	2	2	2
8	20709010	272518	滑块	Block	1	1	1
9	20704011	272514-92	送料曲柄	Crank	1	1	1
10	S05018	4533	螺钉M6 × 0.75 × 12	Screw	1	1	1
11	20710005	272515	偏心销	Pin	1	1	1
12	N01004	4805	螺母M5	Nut	1	1	1
13	20628010	240062	送布曲柄销垫圈	Washer	1	1	1
14	20710006	272525	偏心轴	Pin	1	1	1
15	207S13001	7238	螺钉	Screw	1	1	1
16	20722006	240318	O型圈	Gsket	1	1	1
17	20729002	240319	卡簧	Ring	1	1	1
18	001026	201022	O型圈11.5 × 1.5	O Ring	1	1	1
19	20709011	272526	滑柱	Block	1	1	1
20	20708008	240303	挡圈	Collar	2	2	2
21	207S14001	4543	螺钉M4 × 4	Screw	2	2	2
22	20705008	272517	连杆	Link	1	1	1
23	20703016	179160-05	连杆套	Bushing	1	1	1
24	207S12003	7056	螺钉M5 × 13	Screw	1	1	1
25	30228008	204115	垫圈	Washer	1	1	1
26	20706001	----	主送齿牙架	Main Feed Bar	1	1	1
27	xxxxxxx	xxxxxxx	(三、四线)牙齿组件	Main Feed Dog Complete	1	1	1
28	xxxxxxx	xxxxxxx	主送齿	Main Feed Dog	1	1	1
29	xxxxxxx	xxxxxxx	辅助齿	Auxiliary	1	1	1
30	207S11029	7010	螺钉M3 × 6	Screw	1	1	1
31	S01029	7013	螺钉M3.5 × 7.5	Screw	1	1	1
32	20706002	272528	差动齿牙架	Differential Feed Bar	1	1	1
33	xxxxxxx	xxxxxxx	差动齿	Differential Feed Dog	1	1	1
34	S01029	7013	螺钉M3.5 × 7.5	Screw	1	1	1
35	20709012	272524	滑块	Block	1	1	1
36	20701011	272519	牙架挡块(右)	Feed Bar	1	1	1
37	207S13006	7110	螺钉M4 × 9	Screw	2	2	2
38	20701012	272520	牙架挡块(左)	Feed Bar	1	1	1
39	207S13006	7110	螺钉M4 × 9	Screw	2	2	2
40	20701013	272522	挡油板	Feed Bar Oil Seal	1	1	1
41	20722007	272521	牙架油封	Oil Seal	2	2	2
42	207S13007	4573	螺钉M4 × 5	Screw	2	2	2
43	20721009	----	牙架吸油管	Tube	1	1	1
44	20712055	----	油管夹	Clamp	1	1	0
44	20712062	----	油管夹	Clamp	0	0	1
45	207S11011	7018	螺钉M4 × 5	Screw	1	1	1
46	400044	----	牙架组件	Feed Bar Assy.	1	1	1

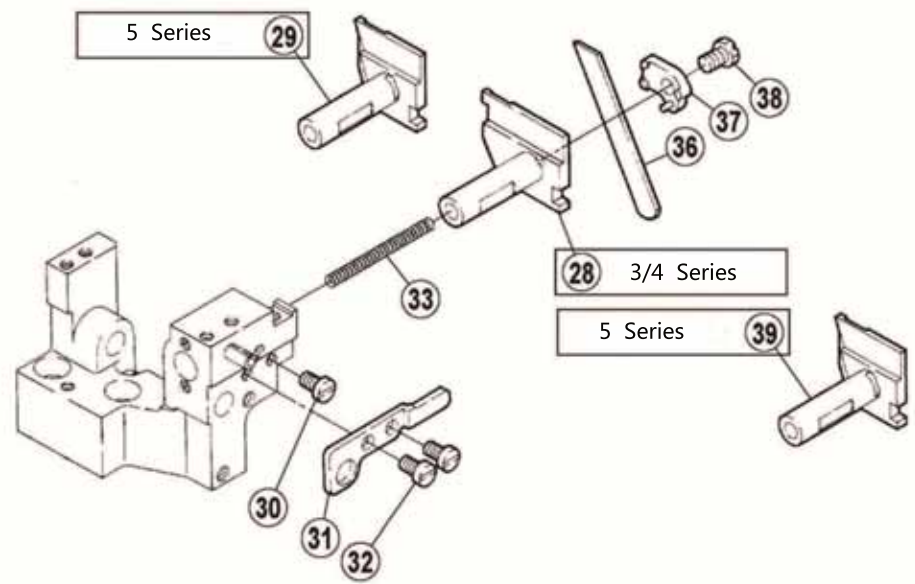
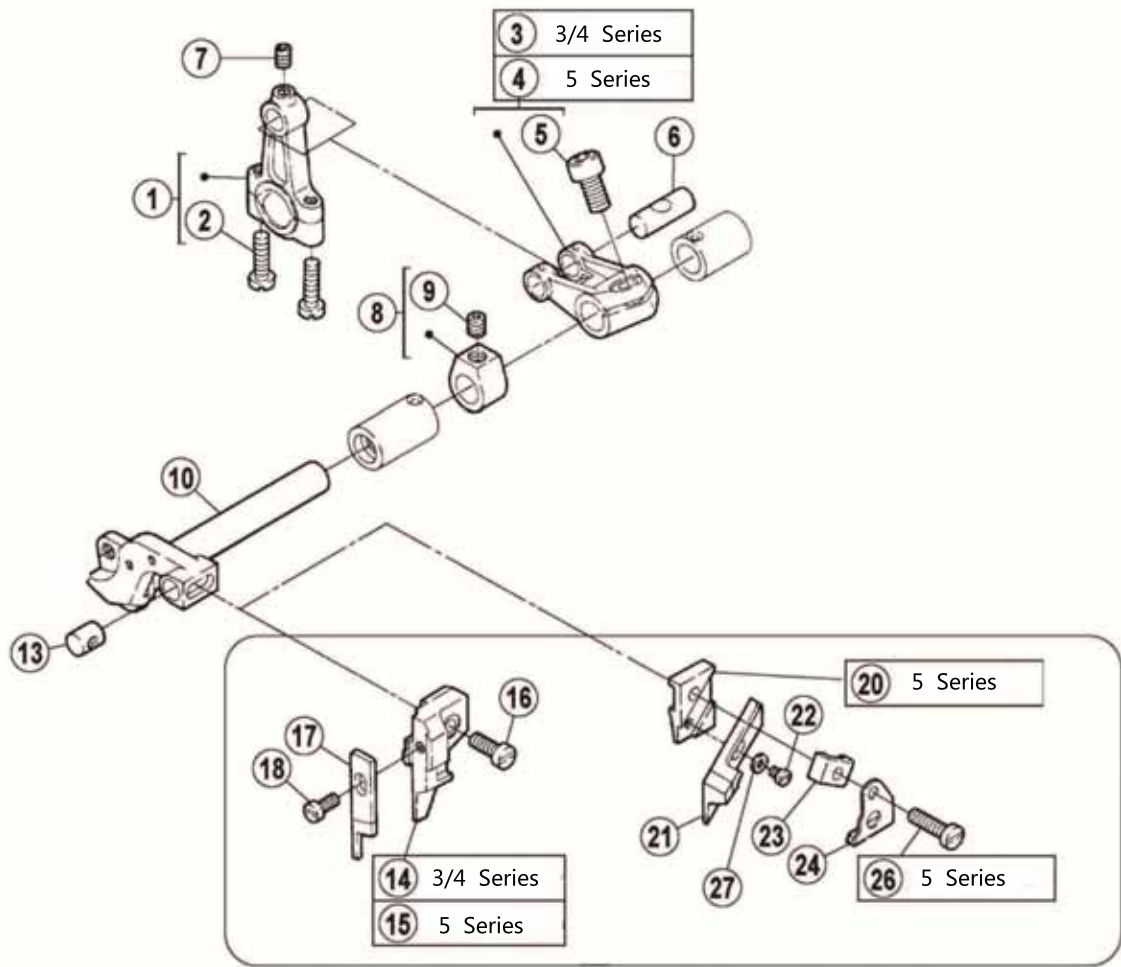

十八、剪布机构/Knife Drive Mechanism

序号 NO.	公司件号 Part NO.	参考件号 Ref.Part No.	名称	Description	数量 (Number)		
					三线 three-thread	四线 four-thread	五线 five-thread
1	400041	273000-92	上刀连杆	Connection	1	1	1
2	207S11016	7023	螺钉M4 × 16	Screw	2	2	2
3	20704012	273001-92	上刀曲柄	Crank	1	1	0
4	20704030	273002-92	上刀曲柄	Crank	0	0	1
5	S05018	4533	螺钉M6 × 0.75 × 12	Screw	1	1	1
6	20626003	271001	曲柄销	Pin	1	1	1
7	207S14007	4538	螺钉M4 × 6	Screw	1	1	1
8	30208001	240235-92	挡块	Collar	2	2	2
9	S10003	4547	螺钉M6 × 0.75 × 5	Screw	2	2	2
10	20702009	273003	上刀架轴	Upper Knife Lever	1	1	1
13	20726005	273006	导向销	Pin	1	1	1
14	20701014	179712-05	上刀座	Upper Knife Clamp	1	1	0
15	20701036	179713-05	上刀座	Upper Knife Clamp	0	0	1
16	207S11012	7020	螺钉M4 × 10	Screw	1	1	1
17	xxxxxxxx	xxxxxxxx	上刀	Upper Knife	1	1	1
18	S01029	7013	螺钉M3.5 × 7.5	Screw	1	1	1
20	20701050	210757	绞刀安装板	Angled Upper Knife Clamp	0	0	1
21	xxxxxxxx	xxxxxxxx	切刀	Angled Upper	0	0	1
22	207S11020	7008	螺钉M3 × 4	Screw	0	0	1
23	20712053	210758	上刀凹角切	Angled Upper Knife Gib	0	0	1
24	20712051	179341-15	挡板	Waste Guard	0	0	1
26	S11025	----	螺钉M4 × 20	Screw	0	0	1
27	W01011	----	垫圈	Washer	0	0	1
28	20701015	273008	下刀架	Lower Knife Holder	1	1	0
29	20701037	273009	下刀架	Lower Knife Holder	0	0	1
30	S01010	7019	螺钉M4 × 8	Screw	1	1	1
31	20712021	273010	挡板	Lower Knife Holder Guard	1	1	1
32	207S11019	7082	螺钉M4 × 7.5	Screw	2	2	2
33	20727006	240324	弹簧	Spring	1	1	1
34	20712022	273007	挡板	Plate	1	1	1
35	207S11007	7019	螺钉M4 × 7.5	Screw	1	1	1
36	xxxxxxxx	xxxxxxxx	下刀	Lower Knife	1	1	1
37	20709013	273012	压板	Lower Knife Clamp	1	1	1
38	207S12004	7173	螺钉M5 × 8	Screw	1	1	1
39	20701052	179712-05	上刀座 (H)	Upper Knife Clamp (H)	0	0	1

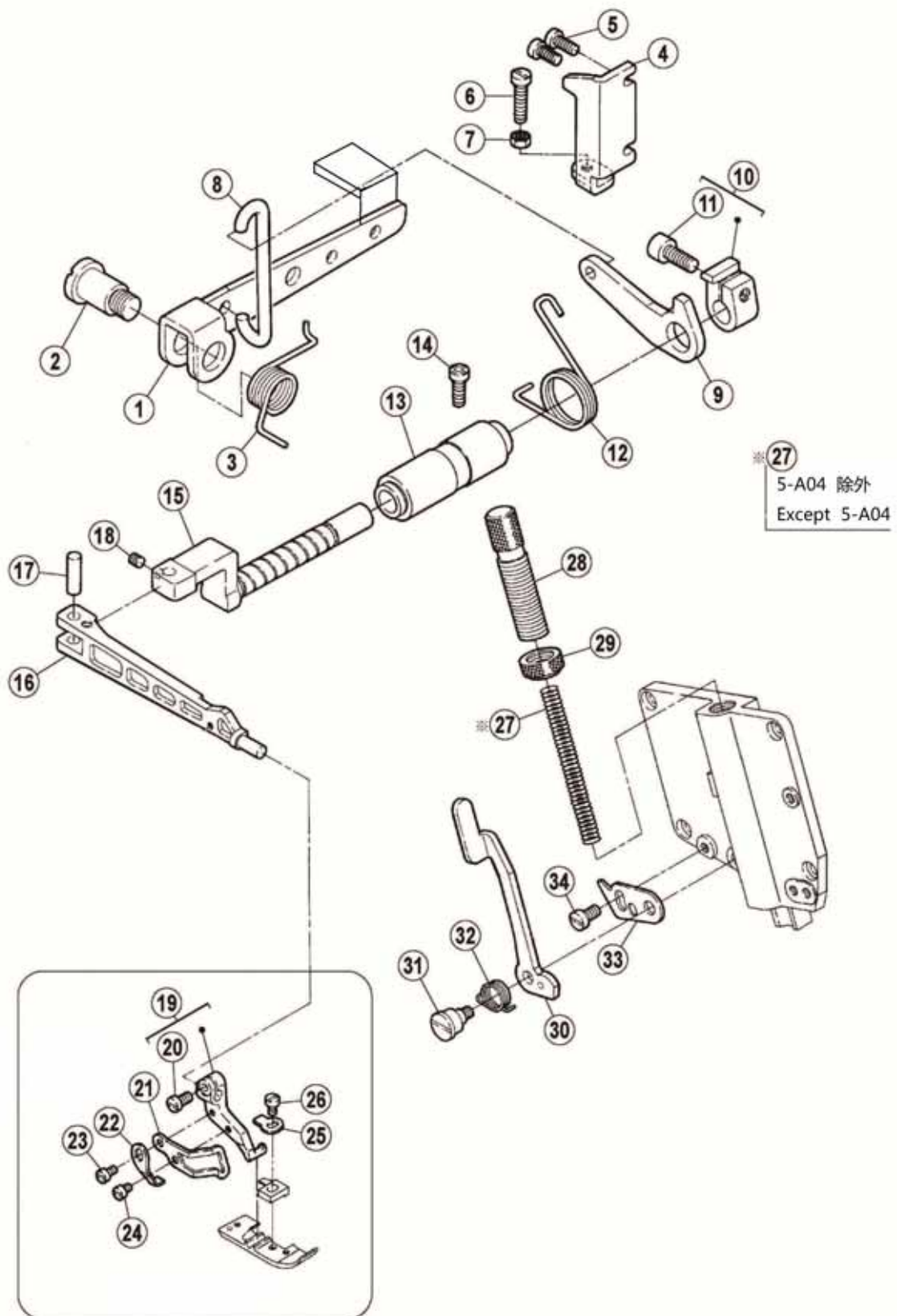

十九、抬压脚机构/Presser Foot Mechanism

序号 NO.	公司件号 Part NO.	参考件号 Ref.Part No.	名称	Description	数量 (Number)		
					三线 three-thread	四线 four-thread	五线 five-thread
1	20712079	274007	抬压脚杠杆	Lever	1	1	1
2	207S20008	7060	抬压脚螺钉M10	Screw	1	1	1
3	20727007	274008	扭簧	Spring	1	1	1
4	20712024	274009	角板	Stopper	1	1	1
5	207S11012	7020	螺钉M4 × 10	Screw	2	2	2
6	207S11031	7175	螺钉M5 × 24	Screw	1	1	1
7	N01004	4805	螺母M5	Nut	1	1	1
8	20712025	274006	弯钩	Link	1	1	1
9	20612030	274004	抬压脚小杠杆	Lever	1	1	1
10	20608004	274003-92	抬压脚复位圈	Collar	1	1	1
11	S05017	4534	螺钉M6 × 0.75 × 13.5	Screw	1	1	1
12	20627009	274005	小杠杆扭簧	Spring	1	1	1
13	20703014	274002	压脚轴套	Bushing	1	1	1
14	207S11016	7023	螺钉M4 × 16	Screw	1	1	1
15	20702010	274001	压脚轴	Shaft	1	1	1
16	20701016	274000-B	压脚臂	Presser Arm	1	1	1
17	20626016	208549	压脚臂连杆销	Pin	1	1	1
18	S10011	4594	螺钉M4 × 0.5 × 4	Screw	1	1	1
19	xxxxxxxx	xxxxxxxx	压脚组件	Presser Foot Assy.	1	1	1
20	207S11030	7013	螺钉M3.5 × 7.5	Screw	1	1	1
21	20712026	274033	压脚护手	Finge Guard	1	1	1
22	20712048	274020	板簧	Stopper	1	1	1
23	207S11009	7009	螺钉M3 × 4.5	Screw	1	1	1
24	207S11020	7008	螺钉M3 × 4	Screw	1	1	1
25	20712027	274019	垫片	Flat Spring	1	1	1
26	207S11032	5089	螺钉M4 × 3.8	Screw	1	1	1
27	20719054	208773A	压簧	Spring	1	1	1
28	20702014	274014	调节螺柱	Adjusting Screw	1	1	1
29	207S16003	274015	螺母	Nut	1	1	1
30	20612034	274016	压杆扳手	Lever	1	1	1
31	207S20009	7171	螺钉	Screw	1	1	1
32	20627010	274017	压杆扳手扭簧	Spring	1	1	1
33	20712030	274010	挡板	Stopper	1	1	1
34	207S11007	7019	螺钉M4 × 7.5	Screw	1	1	1

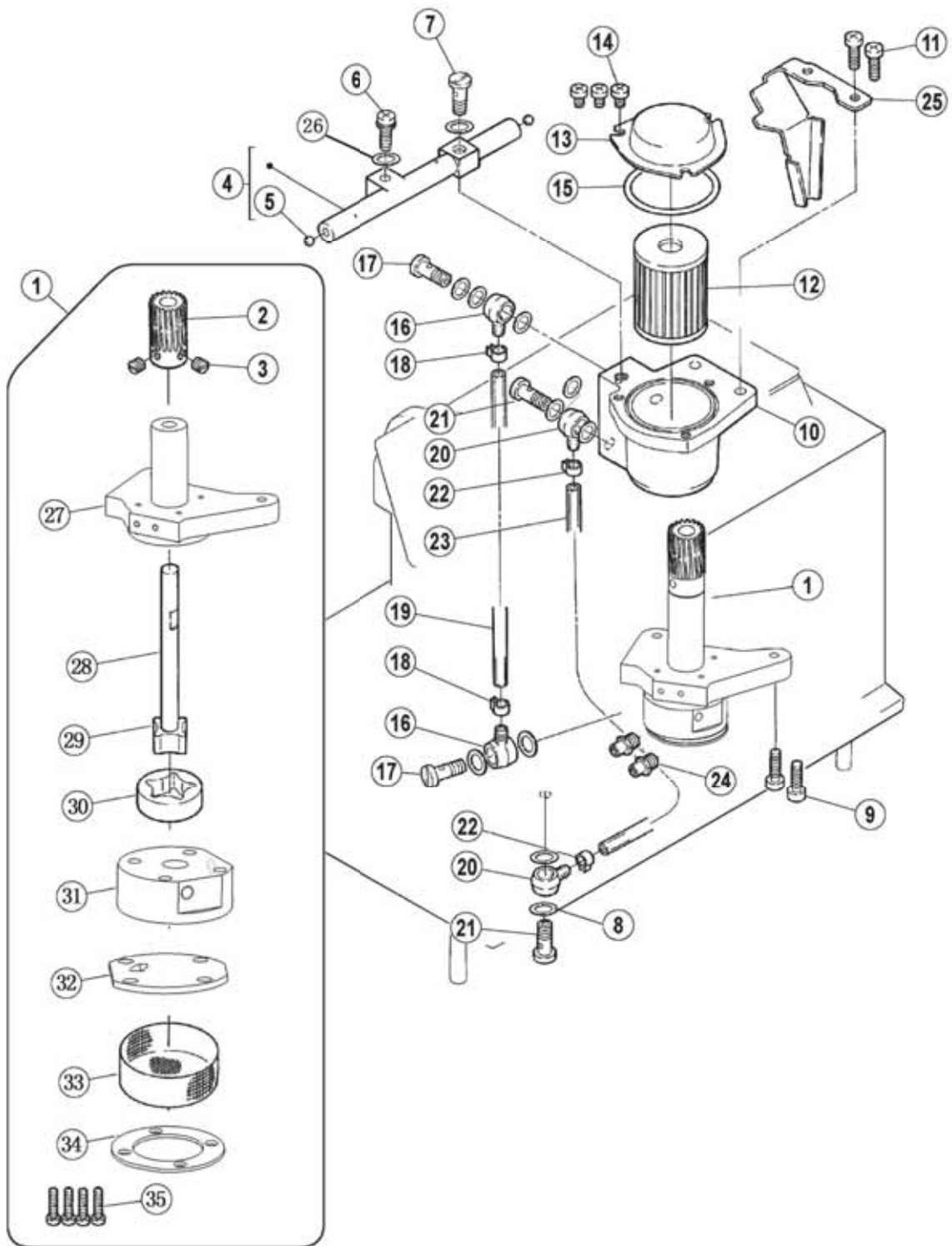

二十、供油机构(1)/ Lubrication Mechanism(1)

序号 NO.	公司件号 Part NO.	参考件号 Ref.Part No.	名称	Description	数量 (Number)		
					三线 three-thread	四线 four-thread	五线 five-thread
1	2072000200	----	油泵组件	Pump	1	1	1
2	20725002	211618	蜗轮	Worm Wheel	1	1	1
3	207S15002	5060	螺钉M8×4.5	Screw	2	2	2
4	2071100900	274515-91	分油器组件	Oil Distributor Complete	1	1	1
5	20709014	210214	滚珠	Plug	2	2	2
6	207S30002	004211-HU0	组合螺钉M4×16	Screw	1	1	1
7	206S30009	240328	过油螺钉	Joint Screw	1	1	1
8	20122033	240263	垫片	Washer	10	10	10
9	207S13008	4529	螺钉M4×16	Screw	2	2	2
10	20701025	274509	油缸	Tank	1	1	1
11	207S11005	7022	螺钉M4×17.5	Screw	2	2	2
12	20136001	----	滤油器	Filter Element	1	1	1
13	20712035	274510	滤油器盖	Cover	1	1	1
14	207S11007	7019	螺钉M4×7.5	Screw	3	3	3
15	001028	240307	O型圈41×1.8	O Ring	1	1	1
16	20636001	200136	油管接头	Joint	2	2	2
17	206S30009	240328	过油螺钉	Joint Screw	2	2	2
18	20729005	202199	油管卡簧	Clamp	2	2	2
19	12921003	240327	油管 5×8	Tube	0.2m	0.2m	0.2m
20	20636001	200136	油管接头	Joint	2	2	2
21	206S30009	240328	过油螺钉	Joint Screw	2	2	2
22	20729005	202199	油管卡簧	Clamp	2	2	2
23	12921003	340327	油管 5×8	Tube	0.31m	0.31m	0.31m
24	20521009	209656A	铜油嘴	Joint	2	2	2
25	20712036	274525	油缸支架	Oil Guide	1	1	1
26	20612062	----	垫片	Washer	1	1	1
27	20720003	----	油泵体	Oil Pump Body	1	1	1
28	20720004	----	转子轴	Rotor Axis	1	1	1
29	20720005	----	上套内转	Inner Rotor	1	1	1
30	20720006	----	上套外转	External Rotor	1	1	1
31	20720007	----	油泵体	Oil Pump Body	1	1	1
32	20720008	----	泵盖	Cover	1	1	1
33	30120010	----	滤油网	Net	1	1	1
34	20720009	----	压网板	Board	1	1	1
35	S05006	----	螺钉M4×25	Screw	4	4	4

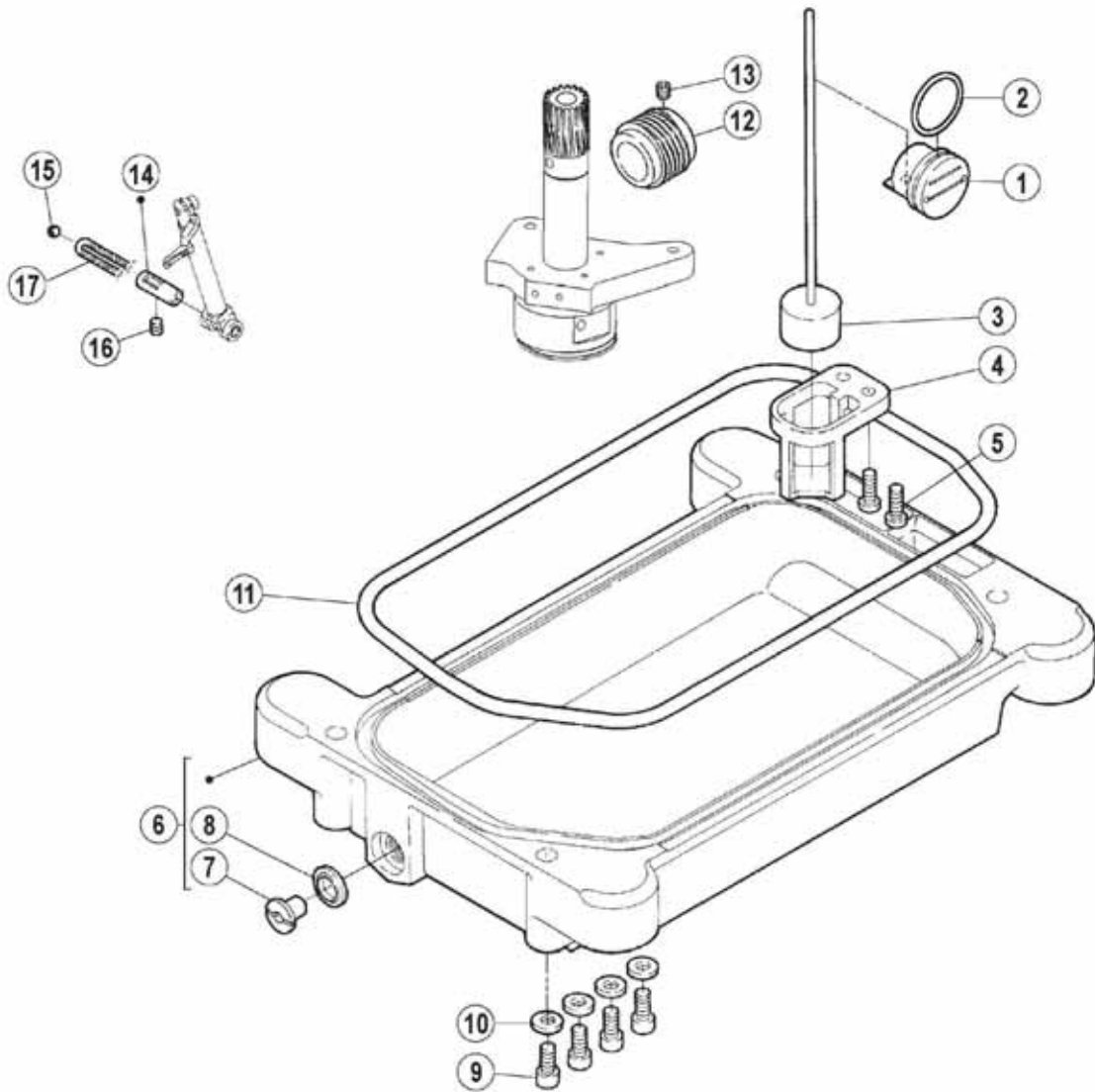
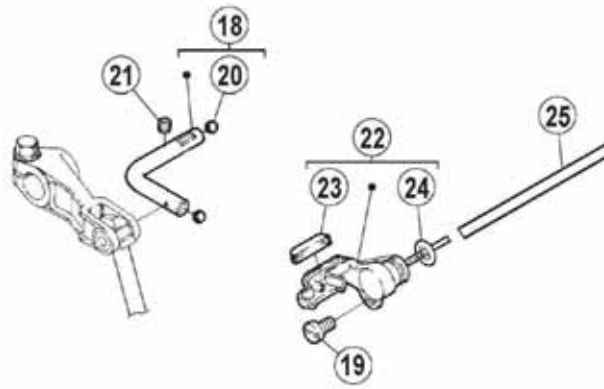

二十一、供油机构(2)/Lubrication Mechanism(2)

序号 NO.	公司件号 Part NO.	参考件号 Ref.Part No.	名称	Description	数量 (Number)		
					三线 three-thread	四线 four-thread	五线 five-thread
1	20711010	----	量油窗A	Oil Sight Gauge	1	1	1
	20711011	----	量油窗B	Oil Sight Gauge	1	1	1
2	o01030	230043	O型圈22×1.5	O Ring	1	1	1
3	2071101200	210193	油标指示组件	Indicator Assy.	1	1	1
4	20711013	210510	托架	Indicator Support	1	1	1
5	207S30002	004211-HU0	组合螺钉M4×16	Screw	2	2	2
6	20701026	274500	油盘	Oil Reservoir	1	1	1
7	207S13002	5138B	放油螺钉	Screw	1	1	1
8	20528014	202287A	油盘放油垫圈	Washer	1	1	1
9	207S13009	4531	螺钉M5×12	Bolt	4	4	4
10	20628018	240339	垫片	Washer	4	4	4
11	20722008	274501	油盘垫	Gasket	1	1	1
12	20725003	274504	蜗杆	Worm	1	1	1
13	207S14006	4514	螺钉M5×5	Screw	1	1	1
14	20626007	274514	上弯针滑杆过滤器	Pipe Assy.	1	1	1
15	20709015	240338	橡胶塞	Rubber plug	1	1	1
16	207S14007	4543	螺钉M4×4	Screw	1	1	1
17	20123021	----	JK795油线	Oil Wick	1	1	1
18	20721010	274513	过油管	Pipe	1	1	1
19	207S11011	7018	螺钉M4×5	Screw	1	1	1
20	20709016	240097	橡胶塞	Rubber plug	2	2	2
21	207S14001	4543	螺钉M4×4	Screw	1	1	1
22	2071203800	274518	吸油嘴组件	Joint	1	1	1
23	20723007	274522	油毡	Felt	1	1	1
24	20622010	204185	差动轴O型圈	O Ring	1	1	1
25	20721011	----	油管 2×4	Tube	0.34m	0.34m	0.34m

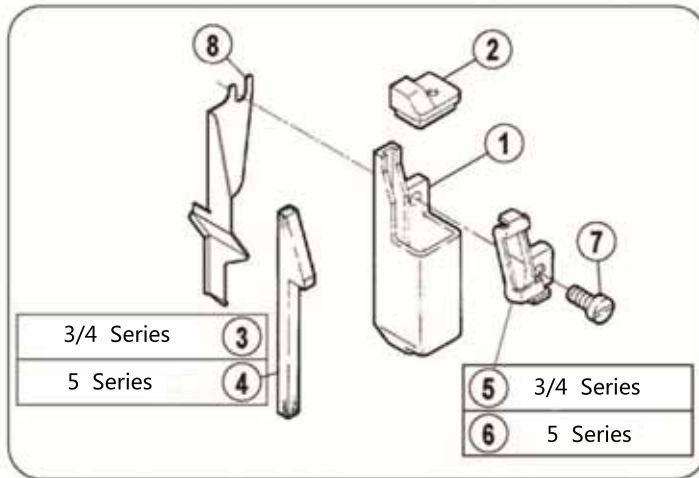

3/4 Series

5 Series

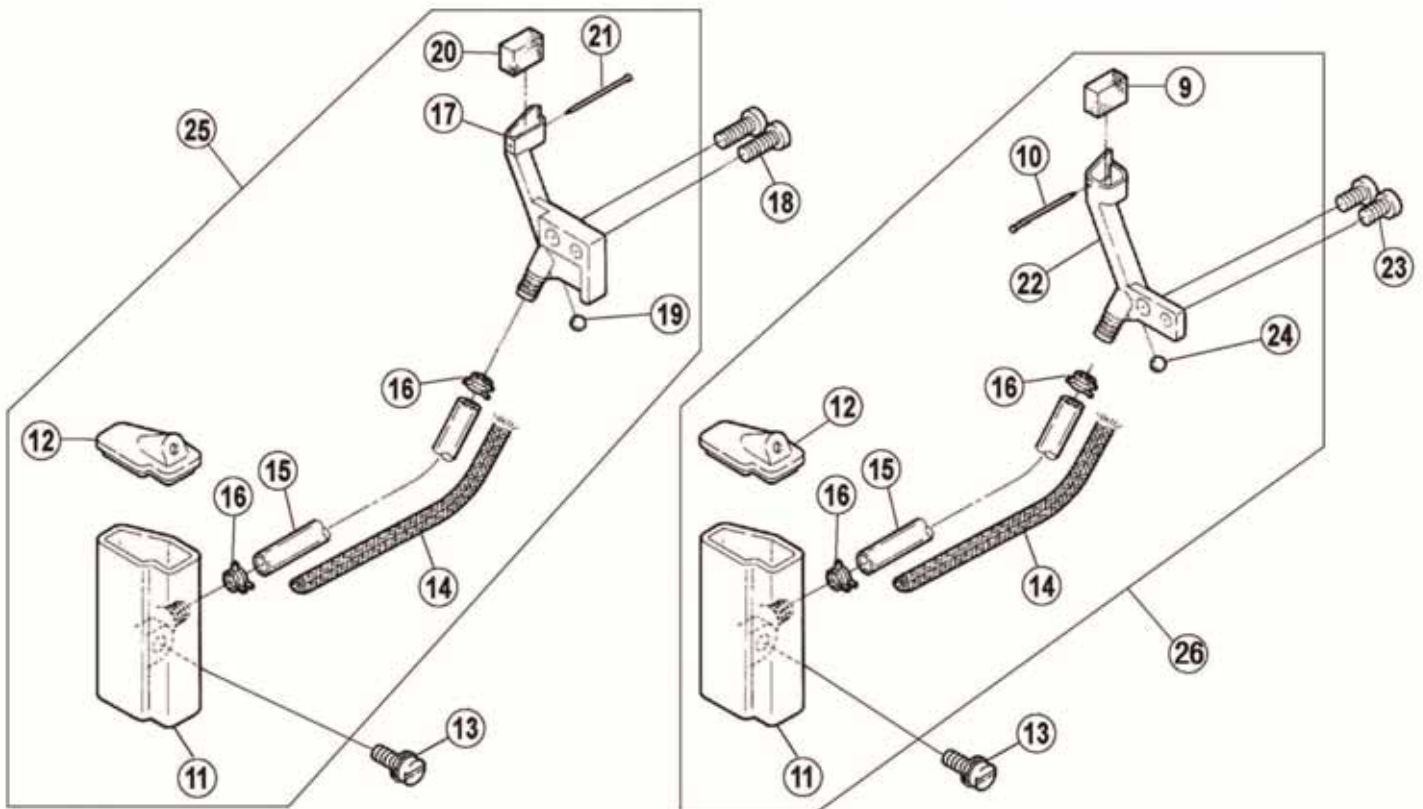

二十二、HR装置机构部件/H. R. Device

序号 NO.	公司件号 Part NO.	参考件号 Ref. Part No.	名称	Description	数量 (Number)		
					三线 three-thread	四线 four-thread	五线 five-thread
1	20711014	275500	上硅油盒	Silicone Oil Reservoir	1	1	1
2	20711015	275501	上硅油盒盖	Cover	1	1	1
3	20723008	275503	油毡	Felt	1	1	0
4	20719051	275546	毛毡	Felt	0	0	1
5	20712040	275502	过线架	Thread Guide	1	1	0
6	20713019	275507	过线架	Thread Guide	0	0	1
7	207S11012	7020	螺钉M4×10	Screw	1	1	1
8	20712042	277888	挡油板	Cover	1	1	1
9	20723009	204466	油毡	Oil Felt	0	0	1
10	20726010	210766	别针	Pin	0	0	1
11	20711016	—	下硅油盒	Silicone Oil Reservoir	1	1	1
12	20711017	275505	下硅油盒盖	Cover	1	1	1
13	207S30003	004210-HU0	组合螺钉M4×12	Screw	1	1	1
14	40123013	202175	油线	Oil Wick	1	1	1
15	40121002	240331	油管	Tube	1	1	1
16	20712041	200155	油管夹	Clamp	2	2	2
17	20701027	275506	针线冷却器	Needle Thread Lubricator	1	1	0
18	207S11008	7021	螺钉M4×10	Screw	2	2	0
19	20709014	210214	滚珠	Plug	1	1	0
20	20723009	204466	油毡	Oil Felt	1	1	0
21	20726010	210766	别针	Pin	1	1	0
22	20701038	275509	针线冷却器	Needle Thread Lubricator	0	0	1
23	207S11007	70196	螺钉M4×7.5	Screw	0	0	2
24	20709014	210214	滚珠	Plug	0	0	1
25	2071101600	—	下硅油盒组件	Silicone Oil Reservoir	1	1	0
26	2070103000	—	下硅油盒组件A	Silicone Oil Reservoir	0	0	1

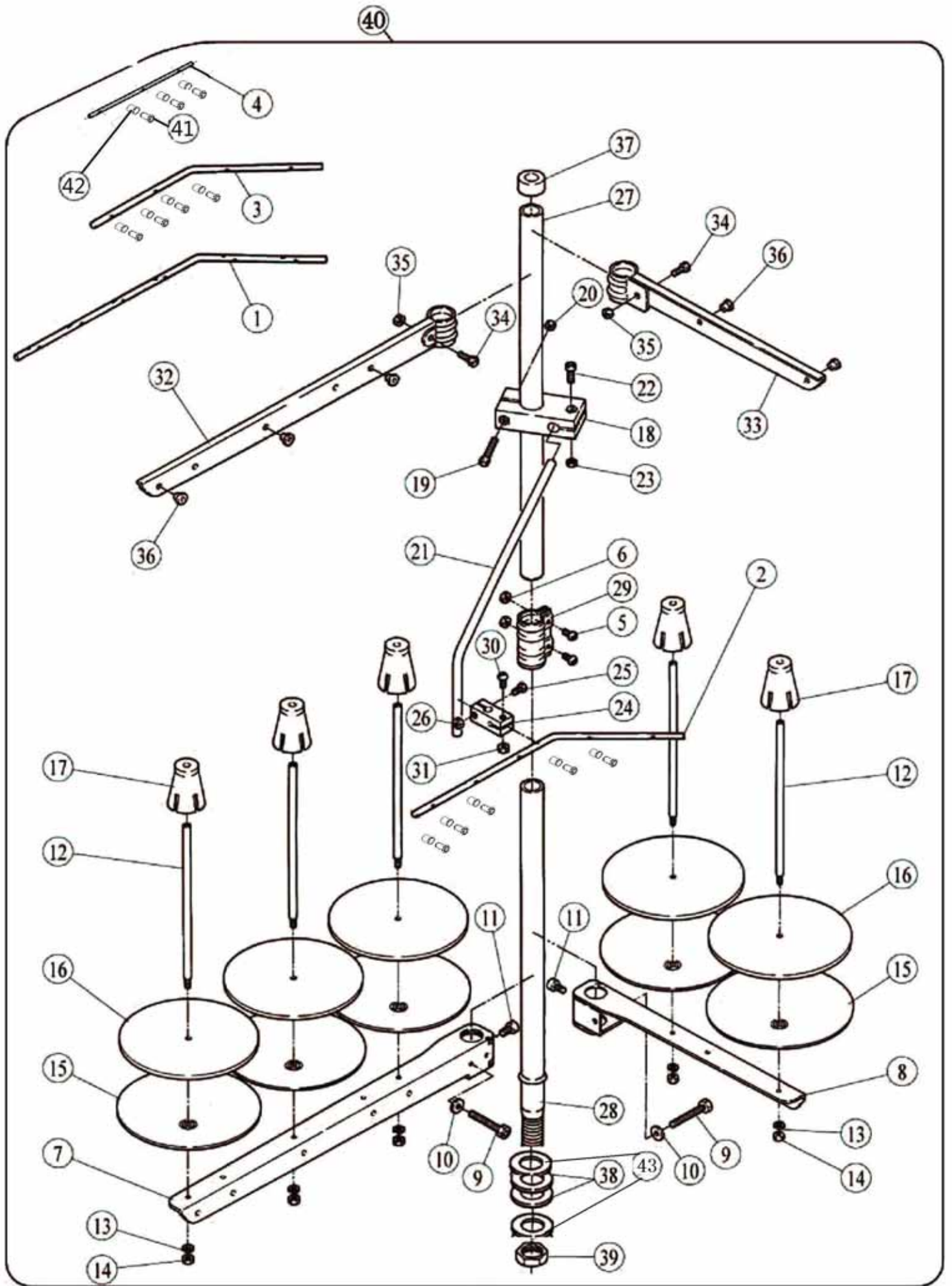

二十三、线架部件/Thread Stand

序号 NO.	公司件号 Part NO.	参考件号 Ref.Part No.	名称	Description	数量 (Number)		
					三线	四线	五线
					three-thread	four-thread	five-thread
1	20631020	4835	过线棒	Thread guide (6-spool)	0	0	1个 (六线用)
2	20131036	293A	过线棒	Thread Guide (5-spool)	0	0	1
3	20131014	293B	过线棒	Thread Guide (4-spool)	0	1	0
4	20131050	293C	过线棒	Thread Guide (3-spool)	1	0	0
5	206S16008	4021	螺钉	Screw	2	2	2
6	N01004	----	螺母M5	Nut	2	2	2
7	30101028	505-PA	长线架	Thread Hanger	1	0	1
8	20631026	505APA	短线架	Thread Hanger	0	2	1
9	206S30025	7102	螺钉	Screw	1	2	2
10	20631032	512	垫片	Washer	1	2	2
11	206S30024	4022	螺钉	Screw	1	2	2
12	20131006	380A	线棒	Spool Pin	3	4	5
13	20631031	201252	垫片	Spring Washer	3	4	5
14	206S16006	4803	螺母	Nut	3	4	5
15	20631025	381-PA	线托盘	Spool Seat Disc	3	4	5
16	20631024	507	托盘垫	Spool Mat	3	4	5
17	20131008	382-PA	线固定套	Spool Cushion	3	4	5
18	30111008	383-PA	棒架	Holder	1	1	1
19	206S30027	4014	螺钉	Screw	1	1	1
20	206S16006	4803	螺母	Nut	1	1	1
21	30113018	384	导线棒	Thread Guide Arm	1	1	1
22	206S30023	4012	螺钉	Screw	1	1	1
23	206S16006	4803	螺母	Nut	1	1	1
24	20631017	233-PA	固定器	Holder	1	1	1
25	206S30023	4012	螺钉	Screw	1	1	1
26	206S16006	4803	螺母	Nut	1	1	1
27	30102034	502-PA	线架上棒	Column Pipe (upper)	1	1	1
28	30102032	503-PA	线架下棒	Column Pipe (lower)	1	1	1
29	30129005	504-PA	锁紧卡固	Joint	1	1	1
30	206S30023	4012	螺钉	Screw	1	1	1
31	206S16006	4803	螺母	Nut	1	1	1
32	30101030	527-PA	长过线架	Thread Hanger	1	0	1
33	30101031	527APA	短过线架	Thread Hanger	0	2	1
34	206S16008	4021	螺钉	Screw	2	2	2
35	N01004	----	螺母M5	Nut	2	2	2
36	30103045	506	过线套	Thread Eyelet	3	4	5
37	30122027	386	棒帽	Rod Cap	1	1	1
38	30128062	509	垫片	Washer	2	2	2
39	206S16007	----	螺母	Nut	1	1	1
40	2063101400	----	线架组件 (三线)	Thread Hanger Assy.	1	0	0
	2053102900	----	线架组件 (四线)	Thread Hanger Assy.	0	1	0
	3013102700	----	线架组件 (五线)	Thread Hanger Assy.	0	0	1
	2053103100	----	线架组件 (六线)	Thread Hanger Assy.	0	0	1 (六线用)
41	20131090		过线管	Thread guide pipe	3	4	5
42	20131112		胶套	Plastic Cover	3	4	5
43	20128038	----	垫片	Washer	2	2	2

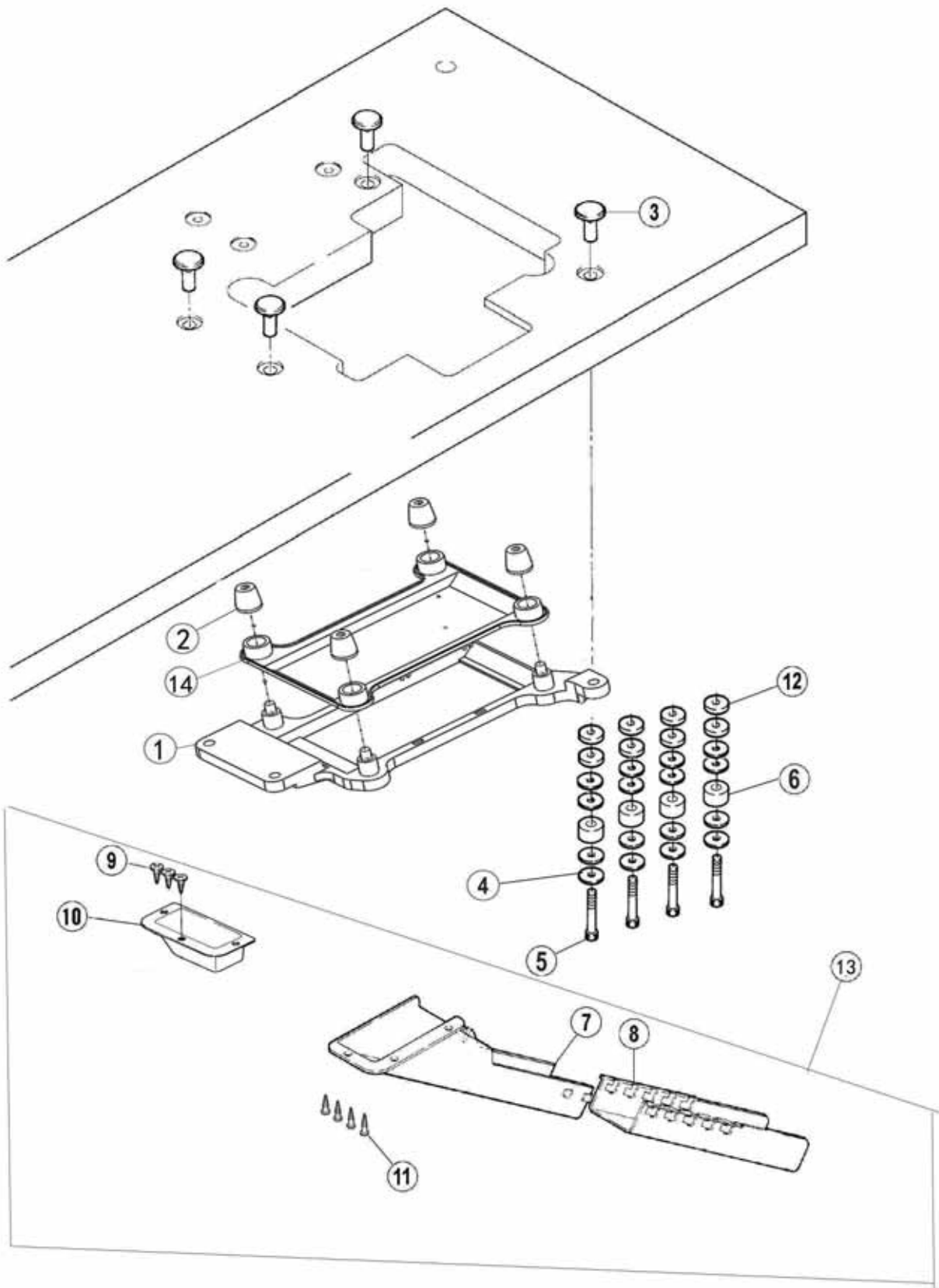

二十四、托盘部件/Part For Semi-Submerged Installation

序号 NO.	公司件号 Part NO.	参考件号 Ref.Part No.	名称	Description	数量 (Number)		
					三线 three-thread	四线 four-thread	五线 five-thread
1	20711054	276001	托盘架	Rest Board	1	1	1
2	20722009	179483-05	托盘防震连接垫	Cushion Rubber	4	4	4
3	20131028	206336	托盘固定螺母	Nut	4	4	4
4	20131029	----	大垫圈	Spacer	16	16	16
5	20131027	4512	托盘内六角螺钉	Screw	4	4	4
6	20131030	----	防震套	Washer	4	4	4
7	20131032	205468-PA	排料槽	Waste Chute	1	1	1
8	20131033	205469-PA	排料槽	Waste Chute	1	1	1
9	20131034	4904	排料槽座螺钉	Screw	3	3	3
10	20131031	205470-PA	排料槽座	Screw	1	1	1
11	20131035	4905	排料槽螺钉	Washer	4	4	4
12	30122031	----	减震垫圈	Spring Washer	8	8	8
13	20131094	----	落料斗组件	Waste Chute Assy.	1	1	1
14	20711052	----	托盘接油盘	oil pan	1	1	1

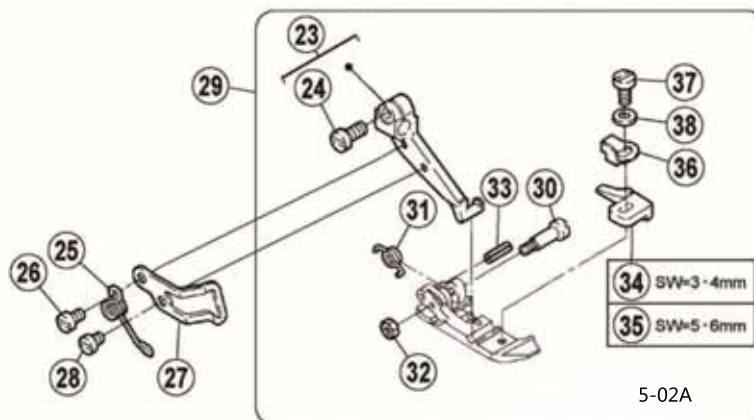
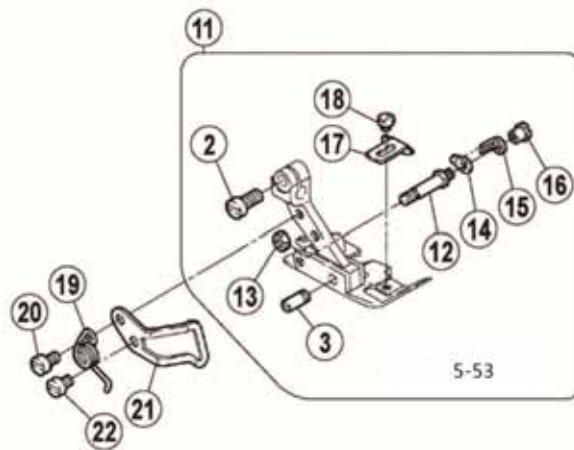
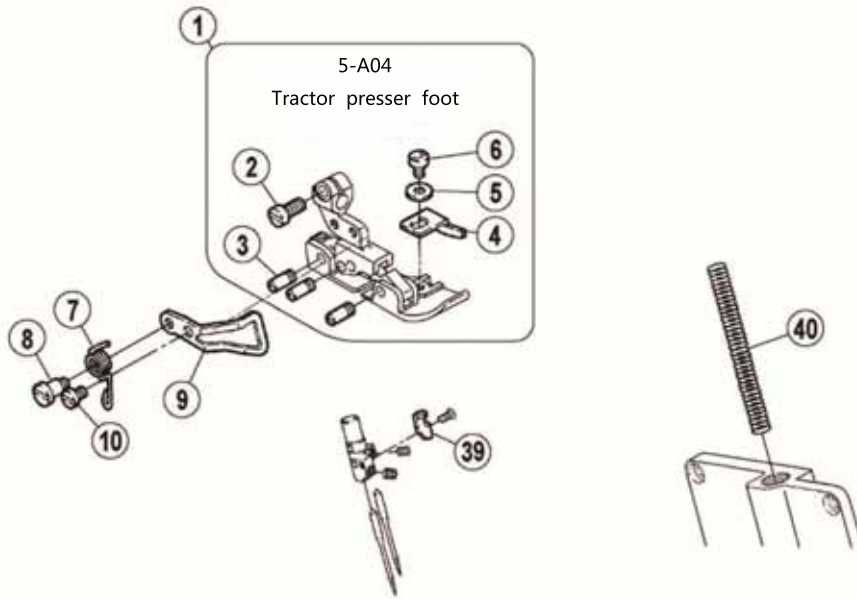

二十五、专用零件/Specific Parts

序号 NO.	公司件号 Part NO.	参考件号 Ref.Part No.	名称	Description	数量 (Number)		
					三线 three-thread	四线 four-thread	五线 five-thread
1	xxxxxxx	xxxxxxx	压脚组件	Presser Foot Assy.	0	0	1
2	207S11030	7013	螺钉M3.5×7.5	Screw	0	0	2
3	20726011	208958-B	销	Pin	0	0	4
4	20714051	277108	护料压板	Fabric Guard	0	0	1
5	W01002	202875	垫圈3	Washer	0	0	1
6	206S11018	5157	螺钉	Screw	0	0	1
7	20719053	274024	压脚弹簧	Spring	0	0	1
8	207S16050	7166	轴位螺钉	Screw	0	0	1
9	20712052	274027	压脚挡片	Finger Guard	0	0	1
10	207S11009	7009	螺钉M3×4.5	Screw	0	0	1
11	xxxxxxx	xxxxxxx	压脚组件	Presser Foot Complete	0	0	1
12	20726012	212499-B	销	Pin	0	0	1
13	207S16004	5409	螺母	Nut	0	0	1
14	20726014	212498	销	Latch	0	0	1
15	20727052	274028	弹簧	Spring	0	0	1
16	207S16005	3153	螺母	Nut	0	0	1
17	20712063	208531	辅助压脚	Fabric Guard	0	0	1
18	207S11034	5030	螺钉M1×2.3	Screw	0	0	1
19	20715057	274022	压脚弹簧	Spring	0	0	1
20	207S11009	7009	螺钉M3×4.5	Screw	0	0	1
21	20712050	274026	压脚护手	Finger Guard	0	0	1
22	207S11020	7008	螺钉M3×4	Screw	0	0	1
23	xxxxxxx	xxxxxxx	压脚组件	Holder	0	0	1
24	207S11030	7013	螺钉M3.5×7.5	Screw	0	0	1
25	20727050	274023	压脚弹簧	Spring	0	0	1
26	207S11009	7009	螺钉M3×4.5	Screw	0	0	1
27	20712049	274025	压脚护手	Finger Guard	0	0	1
28	207S11020	7008	螺钉M3×4	Screw	0	0	1
29	xxxxxxx	xxxxxxx	压脚组件	Presser Foot Complete	0	0	1
30	20726013	211919	销	Pin	0	0	1
31	20727053	211918	弹簧	Spring	0	0	1
32	207S16006	3150	螺母	Nut	0	0	1
33	20729003	211920	销	Spring Pin	0	0	1
34	xxxxxxx	xxxxxxx	压脚爪	Presser Foot	0	0	1
35	xxxxxxx	xxxxxxx	压脚爪	Presser Foot	0	0	1
36	20712064	211917	安装板	Bracket	0	0	1
37	207S11032	5089	螺钉M3.5×5.5	Screw	0	0	1
38	W01002	----	垫片	Washer	0	0	1
39	20713056	275030A	过线板	Thread Eyelet	0	0	1
40	20719054	240347	压簧	Spring	0	0	1

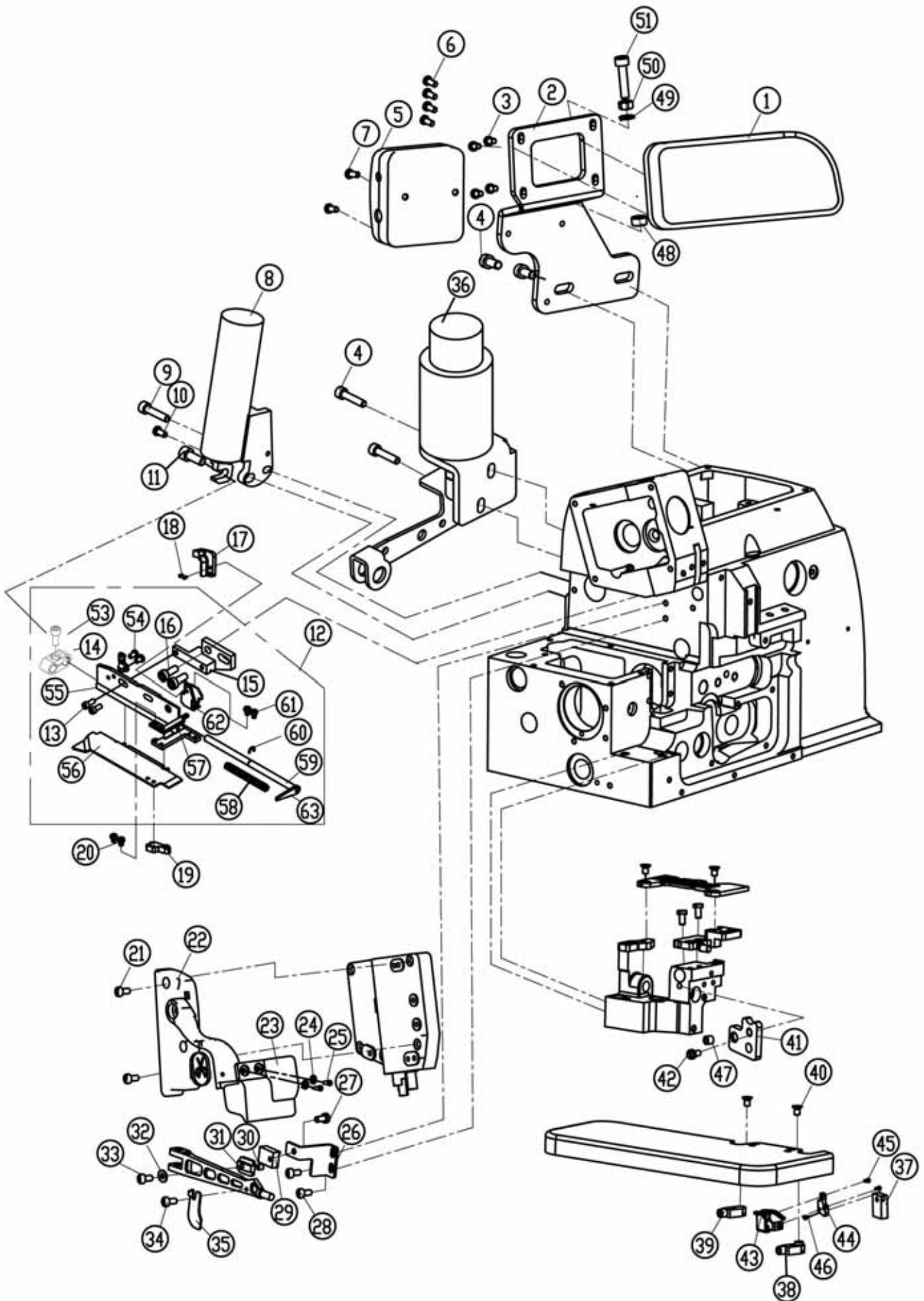

二十六、专用零件/Specific Parts

序号 NO.	公司件号 Part NO.	参考件号 Ref.Part No.	名称	Description	数量 (Number)		
					三线	四线	五线
					three-thread	four-thread	five-thread
1	20730305		操作面板	Operation Panel	1	1	1
2	20712081		面板支架	Operation Panel Installation Plate	1	1	1
3	206S11021		螺钉M4×10	Screw	4	4	4
4	S05232		螺钉M6×12	Screw	2	2	2
5	2071130200		转接盒	Interconnecting device	1	1	1
6	206S11022		螺钉M4×8	Screw	4	4	4
7	207S11007		螺钉M4×7.5	Screw	2	2	2
8	2073001300		电磁铁组件	electromagnet assembly	1	1	1
9	S05023		螺钉M6	Screw	1	1	1
10	207S13006		螺钉M4×9	Screw	1	1	1
11	20726201		销子	Pim	1	1	1
12	2071208200		自动剪线组件	Cutter Assembly	1	1	1
13	201S11019		螺钉M4	Screw M4	2	2	2
14	20704050		刀组连接曲柄	Crank	1	1	1
15	20101302		切刀支撑座	Bracket	1	1	1
16	S05232		螺钉M6×12	Screw	2	2	2
17	20730304		第三发射传感器	Back emission	1	1	1
18	S01027		螺钉M3	Screw	2	2	2
19	20730303		第三接收传感器	Back sensor	1	1	1
20	S02007		螺钉M3×5	Screw	2	2	2
21	S01003		螺钉M4×12	Screw	2	2	2
22	2071130100		开关组件	Trimmer switch sensor	1	1	1
23	20711202		防护罩	Eye guide	1	1	1
24	W01011	2028750	垫片	Washer	2	2	2
25	S01034		螺钉M3×5.7	Screw	2	2	2
26	20712205		安全开关固定支架	Bracket	1	1	1
27	207S11007		螺钉M4×7.5	Screw	1	1	1
28	207S11007		螺钉M4×7.5	Screw	2	2	2
29	20730306		压脚安全开关	Safety Switch	1	1	1
30	30130017		磁铁	Magnetic Iron	1	1	1
31	20701203		磁铁固定块	Bracket	1	1	1
32	20612062		垫片	Washer	1	1	1
33	207S11007		螺钉M4×7.5	Washer	1	1	1
34	207S11020	7008	螺钉M4×4	Washer	1	1	1
35	20712210		切刀挡板	Bracket	1	1	1
35	20712214		切刀挡板(五线厚料)	Bracket	0	0	1
36	2073001600		抬压脚电磁铁	electromagnet assembly	1	1	1
37	20730307		缝台安全开关	Cloth plate assembly	1	1	1
38	20730301		前接收装置	Receiver Attachment (Front)	1	1	1
39	20730302		后接收装置	Receiver Attachment (Back)	1	1	1
40	S02007		螺钉M3×5	Screw	2	2	2
41	20701205		下刀座挡板	Bracket	1	1	1
42	207S11007		螺钉M4×7.5	Screw	1	1	1
43	20712232		锁紧板架	Bracket	1	1	1
44	20712233		安全开关支架	Bracket	1	1	1
45	207S11007		螺钉M4×7.5	Screw	2	2	2
46	207S11007		螺钉M4×7.5	Screw	1	1	1
47	30130017		磁铁	Magnetic Iron	1	1	1
48	20703056		支柱	Brace	1	1	1
49	20728006		垫片	Washer	1	1	1
50	N01020		螺母	Nut	1	1	1
51	S05218		螺钉M5x22	Screw	1	1	1
52					—	—	—
53	207S13006		螺钉 M4×4	Screw	1	1	1
54	S01002		螺钉M4×6.5	Screw	2	2	2
55	20712100		刀组固定座	The fixed seat	1	1	1
56	20712083		缝台挡料板	Gear plate	1	1	1
57	20719004		定刀	Constant dao	1	1	1
58	20727020		弹簧	spring	1	1	1
59	20702070		上刀轴	Knife shaft	1	1	1
60	20629007		卡簧	circlip	1	1	1
61	207S10002		螺钉	Screw	2	2	2
62	20712102		挡料板	Gear plate	1	1	1
63	20719003		动刀	The knife	1	1	1

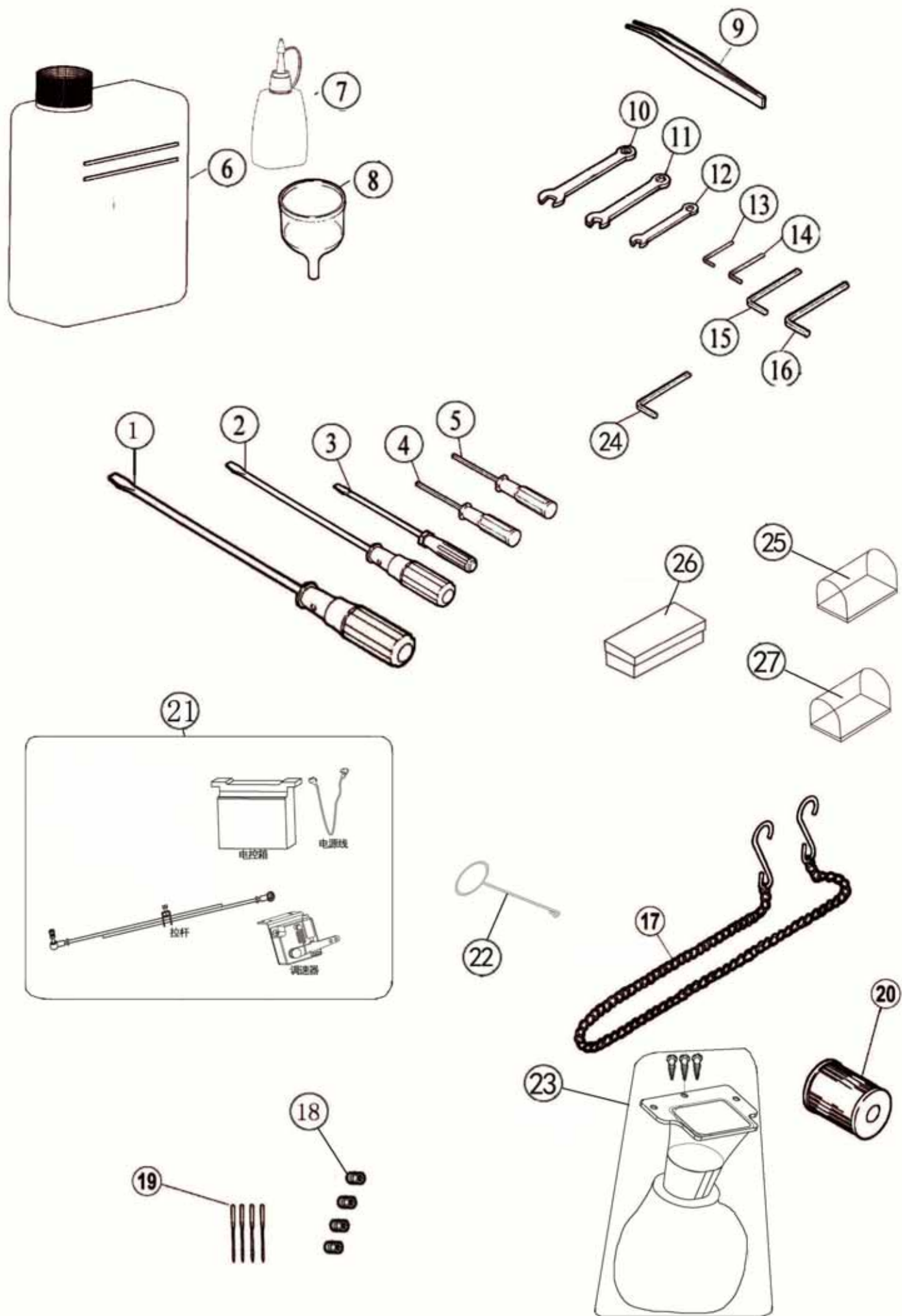

二十七、随机附件部分/Accessories Assemblies

序号 NO.	公司件号 Part NO.	参考件号 Ref.Part No.	名称	Description	数量 (Number)		
					三线 three-thread	四线 four-thread	五线 five-thread
1	10131002	KY15	螺丝刀 (大)	screw driver (L)	1	1	1
2	10131003	KY15	螺丝刀 (中)	screwdriver (M)	1	1	1
3	10131004	KY14	螺丝刀 (小)	Screwdriver (S)	1	1	1
4	20131044	----	直柄内六角螺丝刀 (1.5mm)	Hexagonal wrench/1.5mm	1	1	1
5	20131045	----	直柄内六角扳手 (1.6mm)	Hexagonal wrench/1.6mm	1	1	1
6	20131037	KY02	油壶	Oil container	1	1	1
7	20131038	KY03	小油壶 (尖嘴)	Oil container	2	2	2
8	20131039	KY04	漏斗	Tundish	1	1	1
9	20131051	KY18	镊子	Tweezers	1	1	1
10	20131043	KY09	扳手 (8mm)	Wrench/8mm	1	1	1
11	20131042	KY08	扳手 (7mm)	Wrench/7mm	1	1	1
12	20131041	KY07	扳手 (6mm)	Wrench/6mm	1	1	1
13	20131046	KY10	内六角扳手 (2mm)	Hexagonal wrench/2mm	1	1	1
14	30131012	KY11	内六角扳手 (4mm)	Hexagonal wrench/4mm	1	1	1
15	20131056	KY13	内六角扳手 (6mm)	Hexagonal wrench/6mm	1	1	1
16	30131026	KY19	内六角扳手 (8mm)	Hexagonal wrench/8mm	1	1	1
17	20131054	KY21-A	脚踏板链	Chain	1	1	1
18	S10005	SK216	螺钉	Screw	4	4	4
19	****	----	机针	Needle	4	4	4
20	20136001	KT14-A	滤油器	Filter element	1	1	1
21	2033000200	----	直驱专用部件	DI Special Parts	1	1	1
22	20131052	----	线勾	Needle threader	0	0	1
23	20131115	----	后落料斗组件	Back Waste Chute Assy	1	1	1
24	20131047	KY12	内六角扳手 (5mm)	Hexagonal wrench/5mm	1	1	1
25	10131005	KY01	机头罩	Machine head cover	1	1	1
26	20131055	----	附件盒	Attachment box	1	1	1
27	20131062	----	机头塑料袋	Plastic machine head bag	1	1	1

900E系列标准零件度量表

900E SERIES GAUGE PART SLIST

机型 MACHINE TYPE /SPEC	间距 GAUGE		针板 NEEDLE PLATE	主送齿部件 MAIN FEED DOG ASS	主送齿 MAIN FEED DOG	辅送齿 AUX FEED DOG	差动齿 DIFF FEED DOG	压脚组件 PRESSER FOOT ASS	压脚爪 FRESSER FOOT FINGER	上弯针 UPPER LOOPER	下弯针 LOWER LOOPER
	NG	SW									
JK-903E-02/233	—	4	20715203	2071400100	—	—	—	2071600500	—	20717004	20717006
JK-903E-32R2/223	—	1.5	20715203	—	20714008	—	20714007	2071601000	—	20717004	20717006
JK-904E-M03/333	2	4	20715201	2071400100	—	—	—	2071609400	—	20717004	20717005
JK-904E-M03/333/H/M	2	4	20715002	2071400100	—	—	—	2071600200	—	20717050	20700248

型号 MACHINE TYPE /SPEC	间距 GAUGE		上刀		下刀 LOWER KINIFE	护针		针夹 NEEDLE HOLDER	机针 NEEDLE
	NG	SW	平刀 FLAT NIFE	角刀 ANGLED KNIFE		前 FRONT	后 REAR		
JK-903E-02/233	—	4	20619002	—	20619003	20717001	20717002	20734001	DC×27#9
JK-903E-32R2/223	—	1.5	20619002	—	20619003	20717001	20717002	20734001	DC×27#9
JK-904E-M03/333	2	4	20619002	—	20619003	20717001	20717002	20734002	DC×27#9
JK-904E-M03/333/H/M	2	4	20619002	—	20119002	20717001	20717002	20734002	DC×27#9



机型 MACHINE TYPE /SPEC	间距 GAUGE		针板 NEEDLE PLATE	主送齿部件 MAIN FEED DOG ASS	主送齿 MAIN FEED DOG	辅送齿 AUX FEED DOG	差动齿 DIFF FEED DOG	压脚组件 PRESSER FOOT ASS	上弯针 UPPER LOOPER	下弯针 LOWER LOOPER	链线弯针 CHAINSTITCH LOOPER
	NG	SW									
.JK-905E-03/233	5	5	20715205	2071401700	—	—	—	2071601500	20717004	20717006	20712047
.JK-905E-03/333	3	4	20715204	2071400400	—	—	—	2071600600	20717004	20717006	20712047
.JK-905E-A04/435	5	6	20715206	2071405200	—	—	—	2061604000	20717050	20717006	20717051
.JK-906E-03/333	3	4	20715204	2071400400	—	—	—	2071600600	20717004	20717006	20712047



型号 MACHINE TYPE /SPEC	间距 GAUGE		上刀 UPPER KINIFE		下刀 LOWER KINIFE	护针 NEEDLE GUARO		针夹 NEEDLE HOLDER	机针 NEEDLE
	NG	SW	平刀 FLAT NIFE	角刀 ANGLED KNIFE		前 FRONT	后 REAR		
.JK-905E-03/233	5	5	20619002	—	20619003	20717008	20717002	20734004	DC×27#14
.JK-905E-03/333	3	4	20619002	—	20619003	20717008	20717002	20734003	DC×27#14
.JK-905E-A04/435	5	6	—	20719050	20701053	20717008	20717002	20719056	DC×27#19
.JK-906E-03/333	3	4	20619002	—	20619003	20717008	20717002	20734003	DC×27#14

产品标准代号: QB/T2504-2000
Standard code of the products: QB/T2504-2000



杰克缝纫机股份有限公司

JACK SEWING MACHINE CO.,LTD.

- 公司地址(Address of Company):
台州市椒江区机场南路15号
No. 15 Rd Airport South, Jiaojiang District Taizhou City, Zhejiang, P.R.C
- 国内销售部(Domestic Trade Department):
电话(TEL): 0086-576-88177788 88177789
传真(FAX): 0086-576-88177758
- 国贸部(International Trade Department):
电话(TEL): 0086-576-88177782 88177774
传真(FAX): 0086-576-88177787
- 零件部(Spare Part Department):
电话(TEL): 0086-576-88177798 88177785
传真(FAX): 0086-576-88177775
- 免费售后服务电话(Aftersale Service TEL): 4008876858
<http://www.chinajack.com>
- 资料如有更改, 恕不另行通知, 以实样为准。
You will be not informed if the file has been revised. Please set sample as standard.
- 2015. 9